



CLASS ACTION SETTLEMENT: N54/N54T/N55 ELECTRIC ENGINE COOLANT PUMP

MODEL**Class Vehicles**

E-Series	Model Years	Model Description	Motor
E88	2008, 2009 and 2010	135i Convertible	N54
E88	2011, 2012 and 2013	135i Convertible	N55
E90	2007, 2008, 2009 and 2010	335i and 335xi Sedan	N54
E90	2011	335i and 335xi Sedan	N55
E92	2007, 2008, 2009 and 2010	335i Coupe	N54
E92	2008, 2009 and 2010	335i xDrive Coupe	N54
E92	2011, 2012 and 2013	335is, 335i Coupe and xDrive Coupe	N54T/N55
E93	2007, 2008, 2009 and 2010	335i Convertible	N54
E93	2011, 2012 and 2013	335is and 335i Convertible	N54T/N55
E60	2008, 2009 and 2010	535i Sedan and xDrive Sedan	N54
F10	2011, 2012, 2013, 2014, 2015 and 2016	535i Sedan, xDrive Sedan and ActiveHybrid 5	N55
E61	2008, 2009 and 2010	535i xDrive Sports Wagon	N54
F07	2010, 2011, 2012, 2013, 2014, 2015 and 2016	535 Gran Turismo and xDrive Gran Turismo	N55
F06	2013, 2014, 2015 and 2016	640i Gran Coupe	N55
F06	2014, 2015 and 2016	640i xDrive Gran Coupe	N55
F12	2012, 2013, 2014, 2015 and 2016	640i Convertible	N55
F12	2014, 2015 and 2016	640i xDrive Convertible	N55
F13	2012, 2013, 2014, 2015 and 2016	640i Coupe	N55
F13	2014, 2015 and 2016	640i xDrive Coupe	N55
F01, F02	2011 and 2012	740i and 740Li Sedan	N54
F01, F02	2013, 2014 and 2015	740i, 740Li and 740Li xDrive Sedan	N55
F02	2013, 2014 and 2015	ActiveHybrid 7	N55
E84	2013, 2014 and 2015	X1 xDrive35i	N55
F25	2011, 2012, 2013, 2014, 2015, 2016 and 2017	X3 xDrive35i	N55
F26	2015 and 2016	X4 xDrive35i	N55
F26	2016, 2017 and 2018	X4 M40i	N55
E70	2007, 2008, 2009 and 2010	X5 xDrive30i	N52K
E70	2011, 2012 and 2013	X5 xDrive35i	N55
E71	2008, 2009 and 2010	X6 xDrive35i	N54
E71	2011, 2012, 2013 and 2014	X6 xDrive35i	N55
F16	2015, 2016, 2017, 2018 and 2019	X6 sDrive 35i and xDrive35i	N55
E89	2011, 2012, 2013, 2014, 2015 and 2016	Z4 sDrive35is	N54T
E89	2009, 2010, 2011, 2012, 2013, 2014, 2015 and 2016	Z4 sDrive35i	N54

SITUATION

With the court's FINAL approval, BMW of North America, LLC (BMW NA) has entered a nationwide settlement with the plaintiffs in the following class action: Oliver, et al v. BMW NA, et al

This Settlement is effective on and after Wednesday May 5, 2021

Eligible Class Vehicles

This bulletin applies to Class Members who are the current **owners/lessees of Class Vehicles** that have **not opted-out** of this Settlement, therefore, **accepting** the corresponding Class Member benefit.

The **eligible Class Vehicles** have been updated with the following VIN-specific Vehicle Comment in the DCSnet Warranty Vehicle Inquiry.

Please see SI B01 13 21 (DC 11 51 90 02 00): The current Class Member owner or lessee

and their Class Vehicle are eligible to receive the applicable Service Benefit that is provided through the Electric Engine Coolant Pump (N54 N54T N55 Engine) Class Action Settlement.

Non-Eligible Class Vehicles

Certain Class Members have **opted out** of this Settlement. Those Class Members are **excluded and not eligible** for any of the corresponding Class benefits.

The **non-eligible Class Vehicles** have been updated with the following VIN-specific Vehicle Comment in the DCSnet Warranty Vehicle Inquiry.

SI B01 13 21: The current owner/lessee of this Class Vehicle has opted-out of the Electric Engine Coolant Pump (N54 N54T N55 Engine) Class Action Settlement. By asking to be excluded, the owner/lessee of this vehicle is not eligible to receive any of the Settlements Class benefits.

Note: Before performing a repair and submitting a claim, first confirm that the vehicle has the Eligible Class Vehicle opted-in Vehicle Comment above in the DCSnet Warranty Vehicle Inquiry.

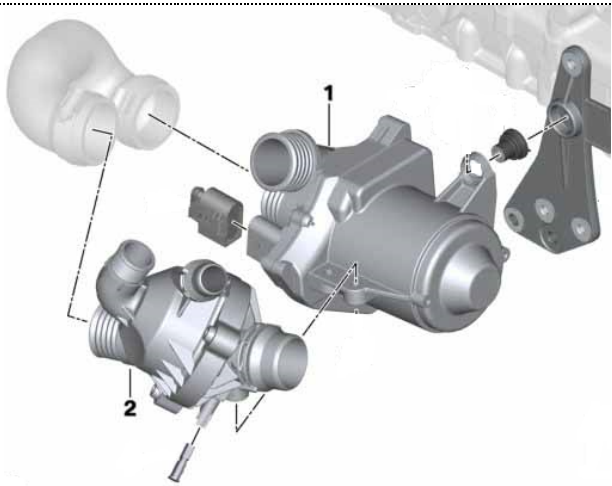

Electric Engine Coolant Pump (N54, N54T, N55 Engines).

(Item #1 Electric Water Pump and #2 Thermostat: E70 X5 xDrive35i N55 components shown)

Settlement Class Vehicles

US-specification MY 2007-2019 BMW vehicles **listed above** that were purchased or leased, registered, and operated in the United States, including the District of Columbia and Puerto Rico.

Settlement Class Members

Are persons or entities who:

1. Currently own or lease a Settlement Class Vehicle that was distributed for sale or lease in the United States, and registered and operated in the United States including the District of Columbia and Puerto Rico; or
2. Formerly owned or leased a Settlement Class Vehicle that was distributed for sale or lease in the United States and registered and operated in the United States including the District of Columbia and Puerto Rico.

Service (Repair) Benefit - Component-Specific Limited Warranty Extension

A. As of the Effective Date of the Settlement (On or after May 5, 2022):

- Except for as specified in B, eligible Settlement Class Members may have a qualifying electrical engine coolant pump on a Class Vehicle replaced **up to the first 7 years/84,000 miles, whichever occurs first.**

B. Up to one (1) year after the Effective Date of the Settlement (From May 5, 2021 to May 4, 2022):

- If a Settlement Class Member's Class Vehicle with an original electric engine coolant pump or a BMW-approved replacement electric engine coolant pump that was installed at a BMW Center, fails within one

(1) year from the Effective Date (regardless of the vehicle age or mileage) it will be replaced under this limited warranty extension.

CAUSE

This Service Information Bulletin provides the information that supports the final Class Action Settlement's Service (Repair) Benefit for the Component Specific Limited Warranty Extension.

CORRECTION

For qualify electric water pump repairs, follow the instructions in the PROCEDURE section.

PROCEDURE

Note: This bulletin is notice of a limited warranty extension, there is no immediate repair required unless the BMW vehicle is currently experiencing this problem.

If an applicable vehicle listed above arrives with an engine malfunction indicator (MIL/Check Engine) warning light on and/or the engine is overheating, performing a Vehicle Test and/or diagnose the cause of the engine overheat.

Based the fault codes stored, the results of the corresponding test modules and/or other diagnosis, replace the engine's electric water pump when required (including engine thermostat if also necessary).

Note: Standalone replacement of the engine thermostat is not included under this extended limited warranty.

Inquiries

The Claims Administrator will address questions related to the Reimbursement Benefits only.

Settlement Updates will also be posted to the settlement website (www.ElectricCoolantPumpSettlement.com) as new information becomes available.

PARTS INFORMATION

Note: This bulletin is notice of a limited warranty extension, there is no immediate repair required unless the BMW vehicle is currently experiencing this problem.

The release of this bulletin should not require you to significantly increase your current inventory of the corresponding replacement parts.

Only order these parts in the quantities needed to address those customers' vehicles that have confirmed failures.

Please refer to the Electronic Parts Catalog (ETK/EPC), using the customer's VIN to locate the applicable replacement part numbers.

Part Number	Description	Quantity
Refer to ETK	Coolant pump, electric	1
Refer to ETK	ASA-Bolt	As applicable
Refer to ETK	Hose clamp	As applicable
And, if necessary:		
Refer to ETK	Thermostat	1
82 14 1 467 704	Antifreeze (1-gallon concentrate)	Sublet as needed

- **Only in conjunction with parts:** When applicable, if ETK/EPC item identifies additional part(s) that must also be replaced/installed in-conjunction with performing a covered repair, these required additional items are also covered under the terms of this extended limited warranty.
- Also refer to ETK/EPC and the repair instructions for onetime-use fasteners/screws and other information regarding repair-related gaskets, seals, fluid and/or lubricants that also need to be replaced/used and claimed.

WARRANTY INFORMATION

Class Member's Class Vehicle's electric engine coolant pumps (N54, N54T, N55) and thermostats (if damaged due to a failure of the electric engine coolant pump) has the following component-specific limited warranty extension:

B. Up to one (1) year after the Effective Date of the Settlement (Repair order/claim dates from May 5, 2021 to May 4, 2022)
--

- Qualifying repairs are covered regardless of the vehicle's time (age) or mileage

A. One (1) year after the Effective Date of the Settlement (Repair order/claim dates, on or after May 5, 2022)

- Qualifying repairs are then covered up to the first 7 years/84,000 miles, whichever occurs first, as determined by the original in-service date

This coverage above applies to eligible US-specification Class Members' Class BMW Model vehicles that are registered, operated, and have their covered repair performed by an authorized BMW center in the United States (including Puerto Rico).

The existing limited warranty coverage for the whole vehicle and other components has not changed.

Qualifying Repairs – Claim Submission

Defect Code:	1151900200	Ex Fx N54 N54T N55 US Electric coolant pump
---------------------	-------------------	--

Applying the following guidelines, select and use the applicable flat rate labor operation(s) from the listing below.

Plus work	The vehicle is already in the workshop for another repair.
Main work	The vehicle arrives at your center for the issue and repair work covered under the terms and conditions described in this bulletin (No other Main work will be performed/claimed during this workshop visit).

Only one Main labor operation can be claimed per workshop repair visit (one or more claim submissions, if applicable).

Labor Operation	Description	Labor Allowance
11 51 000	Removing/installing/replacing coolant pump (Main work)	Refer to AIR
Or:		
11 51 508	Removing/installing/replacing coolant pump (Plus work)	Refer to AIR
Or:		
11 51 504	Removing/installing/replacing coolant pump (Associated work) (coolant already drain in conjunction with performing another repair)	Refer to AIR

And, if also required:

Labor Operation	Description	Labor Allowance
Inclusive Position	Replacing coolant thermostat (Associated work) (Included in 11 51 000,11 51 508,11 51 504)	N/A

And, as necessary:

With Diagnosis/Repair Work Procedures (with 11 51 508 or 11 51 504)

Labor Operation	Description	Labor Allowance
00 00 006	Performing vehicle test (with vehicle diagnosis system – checking faults) (Main work)	Refer to AIR
Or:		
00 00 556	Performing vehicle test (with vehicle diagnosis system – checking faults) (Plus work)	Refer to AIR
And:		
61 21 528	Support voltage of the vehicle electrical system / recharge vehicle electrical system battery	Refer to AIR
And, as applicable:		
61 00 006*	Performing vehicle diagnosis – test module	Work time (WT)
And/or		
61 00 009*	Troubleshooting in the electrical/electronic system	Work time (WT)
Or		
00 58 000*	Diagnosis Worktime Flat Rate (See below)	2 FRU

And in conjunction, if and as necessary:

Labor Operation	Description	Labor Allowance
17 99 000	Additional work related to coolant hoses, lines, and pipes	Work time (WT)
And/or, if necessary		
61 99 000	Additional work related to repairing wiring, pins and/or connector to the water pump	Work time (WT)
And/or, if necessary		
11 99 000	Additional work related to repairing water pump bolt/mechanical connections	Work time (WT)

And/or:

With an External Leak (with 11 51 508 or 11 51 504)

Labor Operation	Description	Labor Allowance
17 00 009	Check the cooling system for watertightness with the special tool (Main work)	Refer to AIR
Or:		
17 00 509	Check the cooling system for watertightness with the special tool (Plus work)	Refer to AIR

Refer to AIR for the corresponding flat rate unit (FRU) allowance.

Work time labor operation codes 61 00 006, 61 00 009, 00 58 000, 17 99 000, 61 99 000 and 11 99 000 are not considered a Main labor operations.

*Based on which applies to your center, please refer to **SI B01 01 20** or **B01 07 20** for claiming your diagnosis work time, job/repair work time, and for the RO/claim repair and work time explanation procedures.

796166

Bulk Materials

Sublet Code 4	See sublet reimbursement calculation below	Reimbursement for the repair-related bulk materials (Do not use the BMW part numbers for claim submission)
------------------	--	--

Sublet reimbursement calculation for claiming the applicable repair-related bulk material (BMW part numbers) is at the dealer net price amount for the quantities used plus your center's handling.

BMW Antifreeze/Coolant: Claim the corresponding sublet dollar amount for the quantity needed to replace what was drained with a 50/50 coolant/water solution.

Enter this material cost in sublet and itemize the amount on the repair order and in claim comment section

Consequential Repair(s) (RO and Claim Comments Required)

When additional work and/or parts are required as a direct result of addressing the issue and/or performing the repair outlined in this Service Information bulletin, claim this additional work/items under the defect code listed above together with the corresponding labor operations listed in the AIR.

Please explain the reason for this consequential repair work (the why and the what) on the repair order and in the claim comments section.

Supporting Materials

[picture as pdf B011320 WP Oliver v BMW_CF_Notice \(11_2020\).pdf](#)