



**PERFORM THE PROCEDURE OUTLINED IN THIS SERVICE INFORMATION ON ALL AFFECTED VEHICLES BEFORE CUSTOMER DELIVERY OR THE NEXT TIME THEY ARE IN THE SHOP FOR MAINTENANCE OR REPAIRS.**

## MODEL

112 (i8)

## SITUATION

The wiring harness for the drive module (rear engine compartment) is routed in close proximity to the ISOFIX reinforcement bracket. During unfavorable conditions, the harness may rub against the bracket. Contact between the harness and bracket may produce a noticeable noise. With longer exposure, the bracket may rub through the corrugated tubing protecting the harness.

## AFFECTED VEHICLES

This Service Action involves certain i8 vehicles within the VIN range VX64073-VX64088.

First check if a Service Action label with a code number **696** is already attached to the A-pillar.

If a code number **696** has been punched out, the Campaign has already been performed and no further action is necessary.

Vehicles which require this Service Action to be completed will show it as "Open" when checked either in the "Service Menu" of DCSnet (Dealer Communication System) or with the Key Reader.

## PROCEDURE

**Only properly trained personnel, who have passed all applicable technical training courses, should perform any maintenance or repairs on any Hybrid or Electric Vehicle. Work performed by unqualified persons may result in severe injury or damage to the vehicle. Additional information may be found in REP 61 00... Observe safety instructions when handling electric vehicles.**

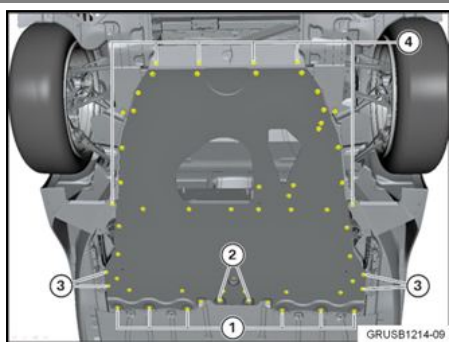

1. Raise the vehicle on a lift.
2. Remove the rear thrust plate per REP 41 11 440.



3. Cut the edge protection into two pieces, 200 mm (approximately 8") long.
4. Secure each edge protection piece to the Carbon Fiber (CFRP) flanges above and below the ISOFIX mount, as shown in red. This is located on the rear bulkhead of the vehicle.

NOTE: The CFRP flange is very sharp, so gloves should be worn for this step.

5. Secure the wire tie retaining clip to the plastic DME bracket as



shown.  
6. Secure the wire tie to the corrugated tube.



7. Verify the installation as shown, which includes:

- Corrugated tubing already present – yellow arrow
- Edge protection on flanges – red lines
- Corrugated tube wire tied to the DME bracket – green circle

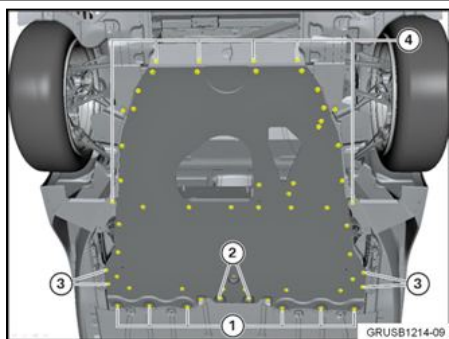

8. Reinstall the thrust plate using new bolts for the forwardmost location (1) and the following torque values:

1. 56 Nm + 90° angle torque
2. 56 Nm
3. 8 Nm
4. 3 Nm
5. All remaining screws – 28 Nm

## PARTS INFORMATION

| Part Number     | Description           | Quantity |
|-----------------|-----------------------|----------|
| 61 13 6 918 644 | Cable tie with holder | 1        |
| 51 72 1 832 146 | Edge protection       | 1        |
| 39 30 6 859 873 | Torx bolt M10X30      | 6        |

## LABEL INSTRUCTIONS



This Service Action has been assigned code number **696**. After the vehicle has been checked and/or corrected, obtain a label (SD 92-439) and:

- Emboss your BMW center warranty number in the middle of the label (1);
- Punch out code number **696** (2), printed on the label; and
- Affix the label to the A-pillar as shown.

If the vehicle already has a label from a previous Campaign, affix the new label next to the old one. Do not affix one label on top of another one because a number from an underlying label could appear in the punched-out hole of the new label.

# WARRANTY INFORMATION

Reimbursement for this Service Action will be via normal claim entry utilizing the following information:

|                         |                         |                          |
|-------------------------|-------------------------|--------------------------|
| <b>Defect Code:</b>     | <b>00 41 59 01 00</b>   |                          |
| <b>Labor Operation:</b> | <b>Labor Allowance:</b> | <b>Description:</b>      |
| 00 62 719               | Refer to KSD2           | Retrofit Edge Protection |

Labor operation code 00 62 719 is a Plus labor operation.