

17 11 000 Removing and installing coolant radiator

Prerequisite

- Switch off ignition.



WARNING

Hot surfaces.

Risk of burning!

- Perform all work only on components that have cooled down.

PRELIMINARY WORK

1 – Removing the cover on the left and right in the top engine compartment



NOTICE

Description is for left component only. Procedure on the right side is identical.

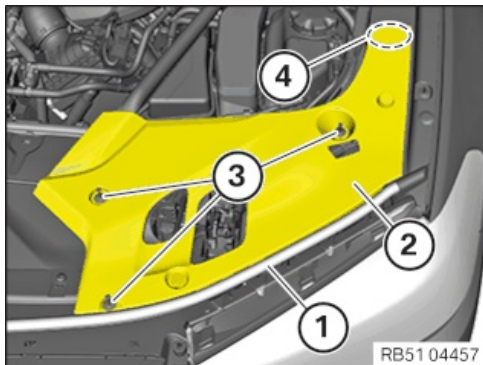

► Remove the cover in the engine compartment on top

- Detach the gasket (1) in the area of the cover (2).
- Loosen the expanding rivet (3).
- Guide out and remove the cover (2) in the area (4).

2 – Remove both front-end struts



NOTICE

Description is for left component only. Procedure on the right side is identical.

► Removing the front-end strut



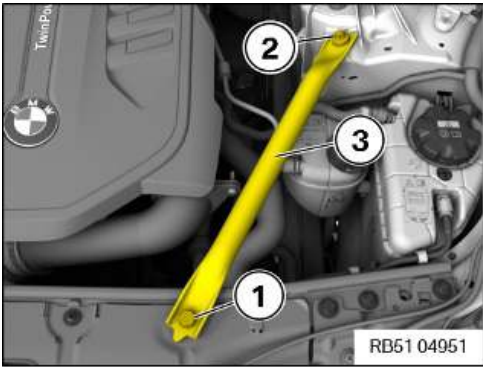

RISK OF DAMAGE

Use of an incorrect tool (impact screwdriver) to release and tighten the screws.

Damaged thread.

- Only use a standard tool (e.g. reversible ratchet) to release/tighten the screw.

- Loosen screws (1) and (2).
- Remove the front-end strut (3).

3 – Remove front cross connection

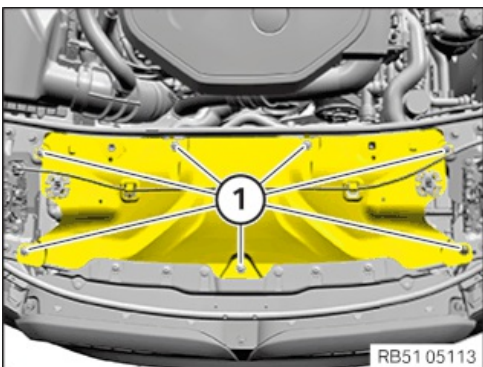

- Loosen screws (1).

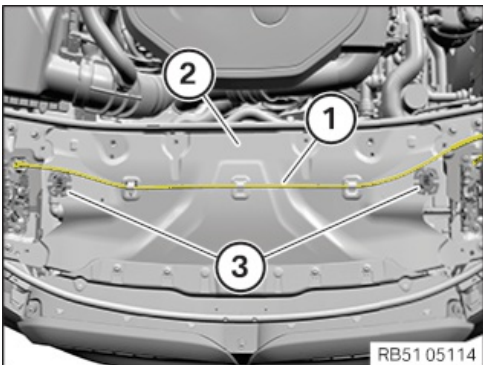

- Detach the Bowden cable (1).
- Feed out cross connection (2) with brackets (3) and remove.

4 – Remove the rear top cross connection

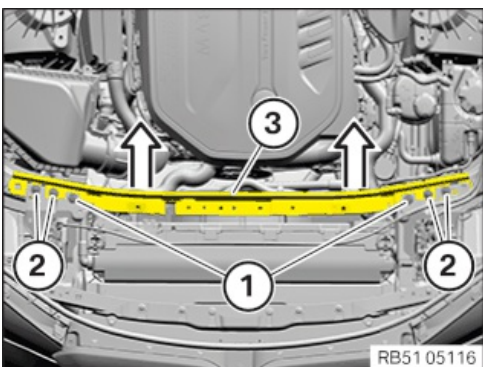

- Loosen screws (1) and (2).
- Guide the cross connection (3) out in the direction of the arrow.

5 – Removing the fan cowl





WARNING

Hot surfaces.

Risk of burning!

- Perform all work only on components that have cooled down.

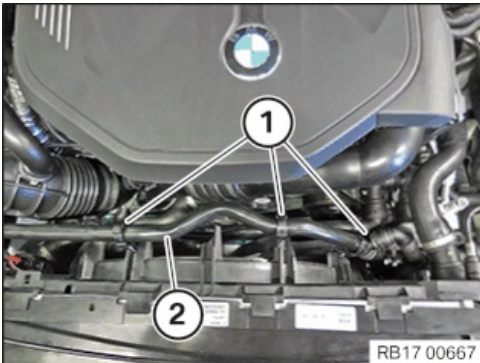

- Unlock and loosen the clamps (1).
- Feed out coolant line (2) and place to one side.

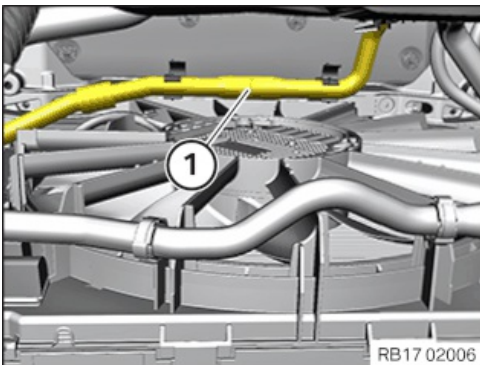

- **If fitted:**

Release the coolant line (1) below at the fan cowl from the clamps and place it to the side.

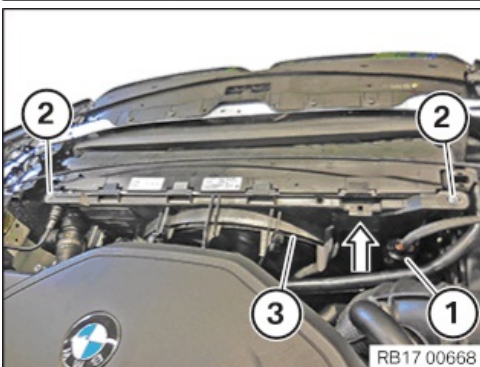

- Unlock and loosen connector (1).
- Loosen screws (2).
- Guide out fan cowl (3) in direction of arrow and remove.

6 – Remove rear underbody protection



NOTICE

To provide a better overview: Schematic diagram with partially hidden components.



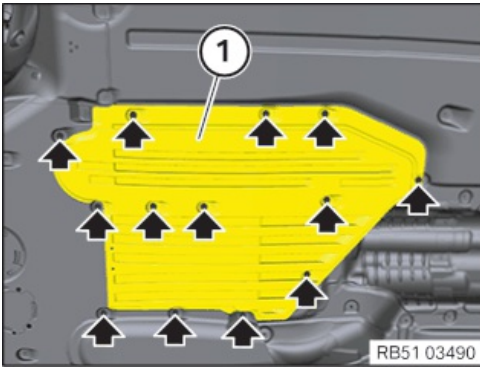

- **Version A:**
Remove screws (arrows).
Feed out the rear underbody protection (1).

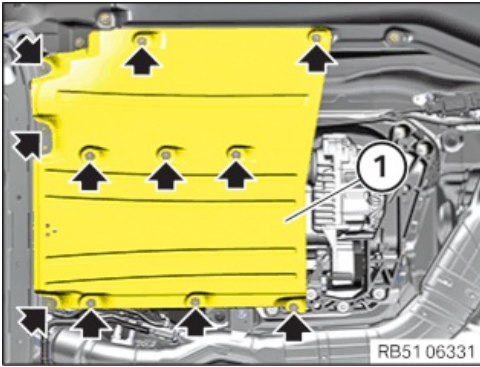

- **Version B:**
Remove screws (arrows).
Guide out rear underbody protection (1) and remove it.

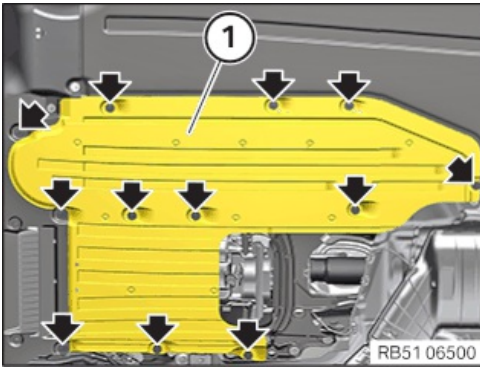

- **Version C:**
Remove screws (arrows).
Guide out rear underbody protection (1) and remove it.

7 – Remove front underbody protection and/or front stiffening plate



TECHNICAL INFORMATION

Different variants may be installed depending on the vehicle equipment.

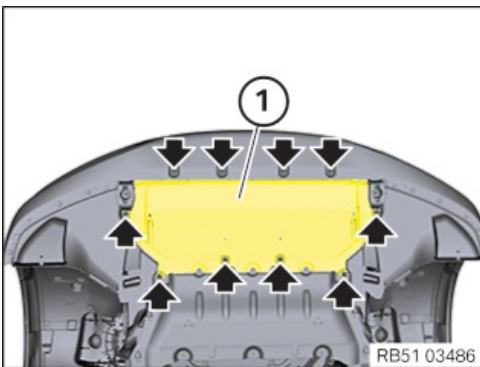

- **Version A:**
Remove screws (arrows).
Feed out the front underbody protection (1).



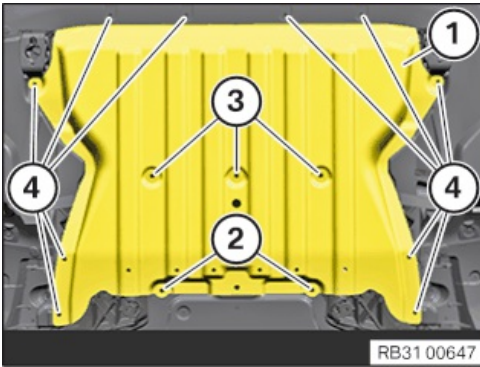

TECHNICAL INFORMATION

Driving without stiffening plate is not permissible.

- **Version B:**
Loosen screws (2) to (4).
Remove the front stiffening plate (1).

8 – Removing the underbody protection of the steering gear and front stiffening plate respectively



TECHNICAL INFORMATION

Different variants may be installed depending on the vehicle equipment.

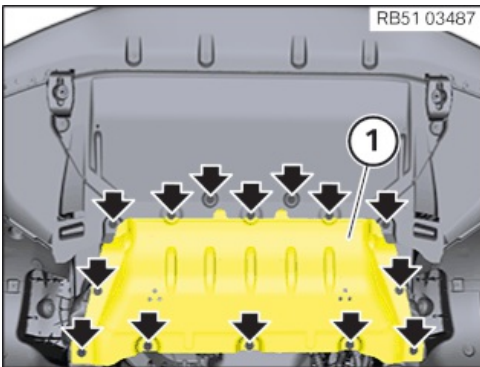

- **Version A:**
Release all bolts (arrows).
Guide out underbody protection (1) of the steering gear.

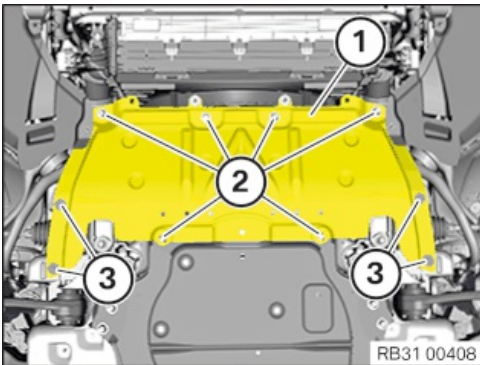

TECHNICAL INFORMATION

Driving without stiffening plate is not permissible.

- **Version B:**
Loosen screws (3).
Loosen screws (2).
Remove front stiffening plate (1).

MAIN WORK

9 – Remove the radiator of the high-temperature coolant circuit



WARNING

Hot surfaces.

Risk of burning!

- Perform all work only on components that have cooled down.





CAUTION

Materials harmful to health.

Contact with fluids harmful to health!

- Note and follow safety information on containers.
- Conduct all work in appropriate personal protective equipment only.



TECHNICAL INFORMATION

Life-long fill of coolant!

Do not reuse used coolant.

When replacing and removing components which rely on the corrosion protection effect of the coolant, it is essential to change the coolant. The cooling system must therefore be emptied and refilled.

In the case of other removal work involving the draining of part quantities of coolant, the coolant level must be topped up with new coolant.



TECHNICAL INFORMATION

Follow notes for repair work on the cooling system.

For additional information see:

Main group 17

17 00 ... Notes for working on the cooling system



TECHNICAL INFORMATION

Collect and dispose of emerging fluids. Observe country-specific waste disposal regulations.

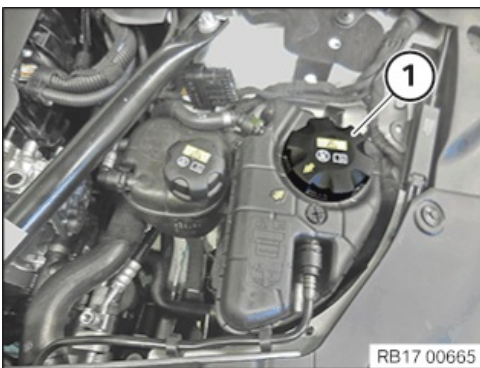

- Loosen sealing cap (1).

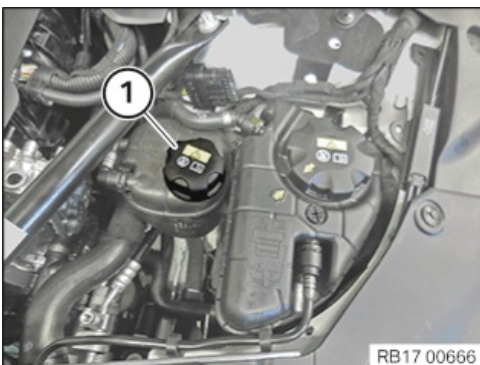

- Loosen sealing cap (1).





RB17 00672

- Unlock the locks (1).
- Unlock the locks (2).
- Remove the cover (3) of the top cooling module.

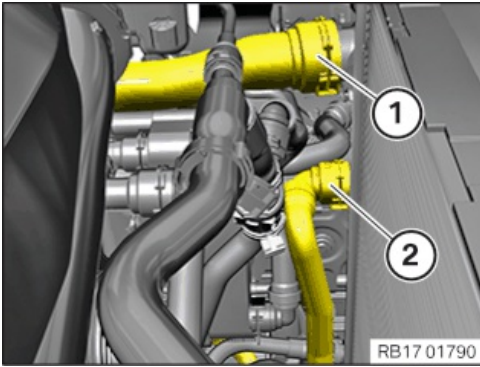

RB17 01790

- Unlock and loosen coolant line (1).
- **Version with external radiator:**
Unlock and disconnect the coolant line (2).
- Catch and dispose of escaping coolant.

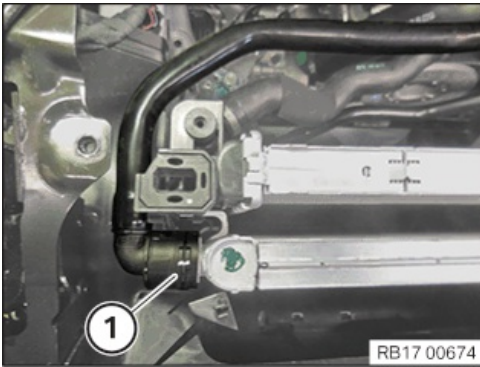

RB17 00674

- Unlock and loosen coolant line (1).
- Catch and dispose of escaping coolant.

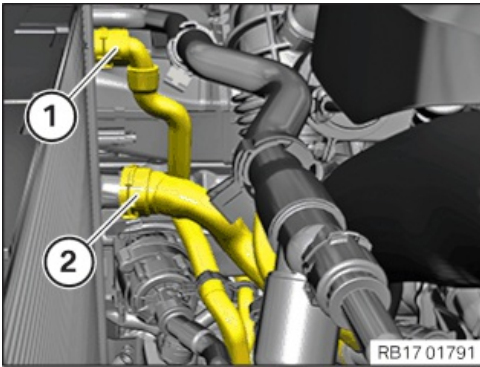

RB17 01791

- Unlock and release the coolant line (1).
- **Version with external radiator:**
Unlock and disconnect the coolant line (2).
- Catch and dispose of escaping coolant.

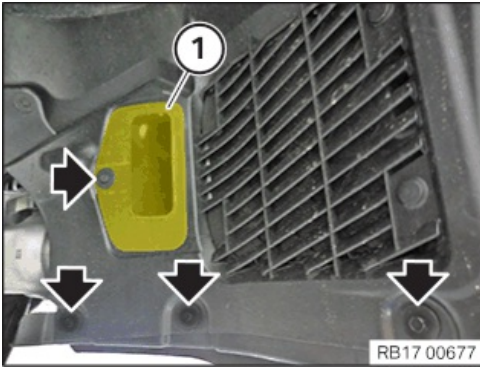

RB17 00677

- Remove screws (arrows).
- Thread out air duct (1) and remove.



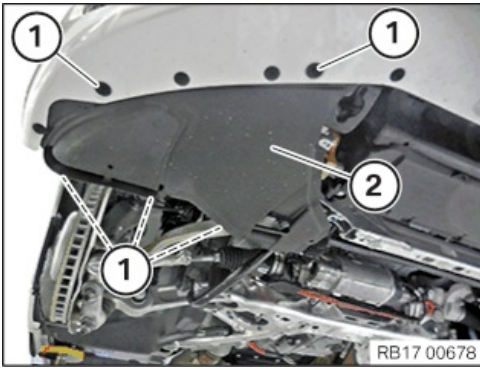

- Loosen clamps .
- Loosen screws (1).
- Guide out and remove the cover (2).

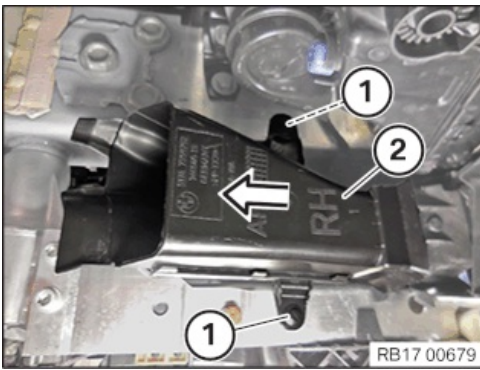

- Loosen clamps (1).
- Guide out air duct (2) in direction of arrow and remove.

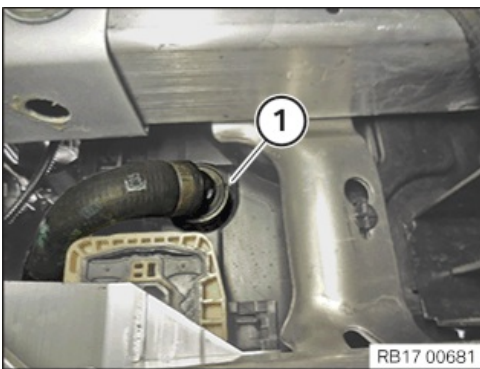

- Unlock and loosen coolant line (1).
- Catch and dispose of escaping coolant.

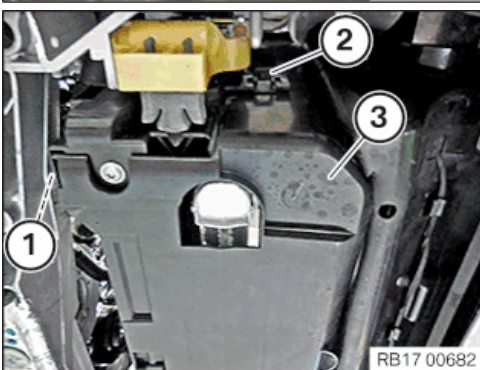

- Unlock lock (1).
- Unlock lock (2).
- Release the cover (3) of the cooling module at the bottom.

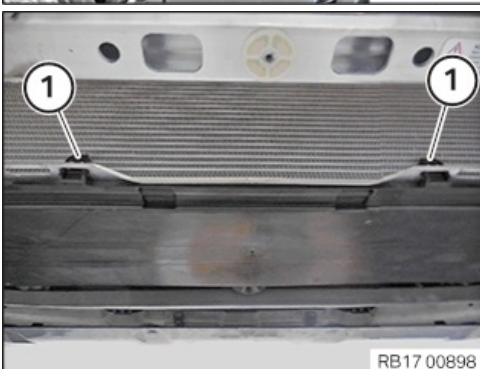

- Unlock the locks (1).



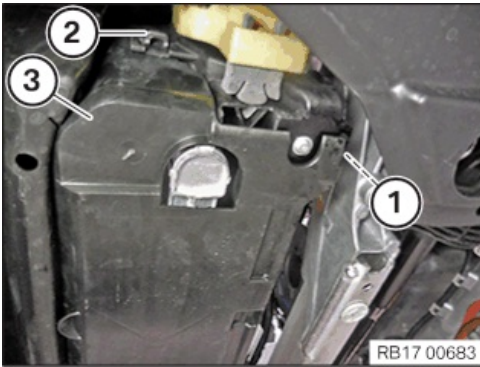

- Unlock lock (1).
- Unlock lock (2).
- Remove the cover (3) of the bottom cooling module.

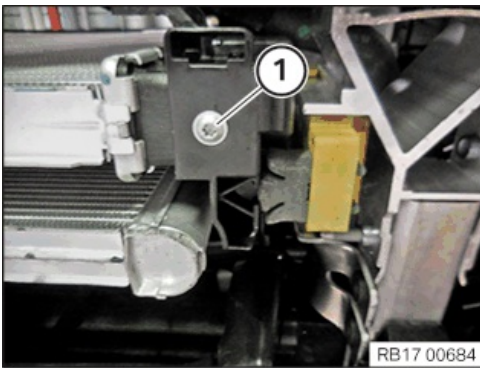

- Loosen screw (1).

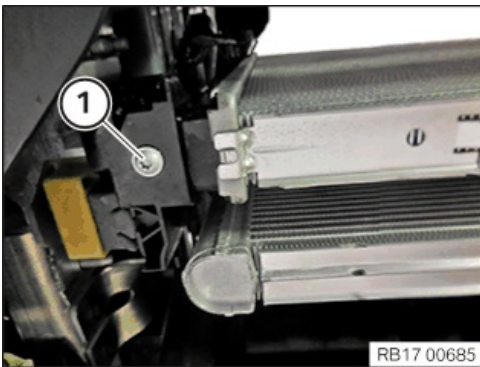

- Loosen screw (1).

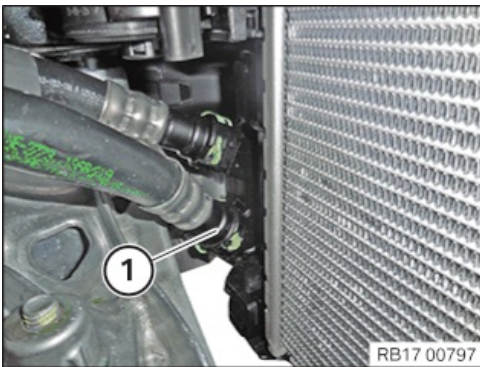

- Unlock the transmission oil feed line (1) and pull it off the transmission oil cooler.
- Catch and dispose of escaping transmission oil.

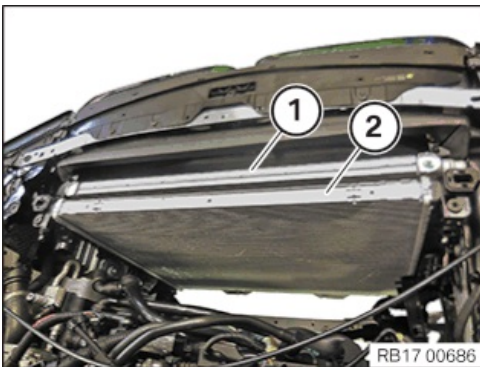

- Remove the radiator of the low-temperature coolant circuit (1) including the radiator of the high-temperature coolant circuit (2).

10 – Renewing the radiator of the high-temperature coolant circuit





- Unlock and loosen the covers (1).

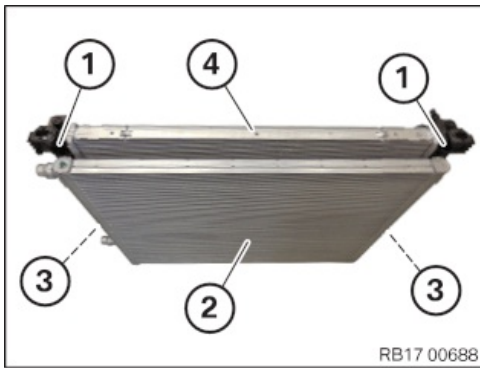

- Unlock the locks (1).
- Guide radiator of low-temperature coolant circuit (2) out of the guides (3) of the radiator of the high-temperature coolant circuit (4) and remove.
- Renew high temperature radiator (4).

Parts: Radiator of high-temperature coolant circuit (4)

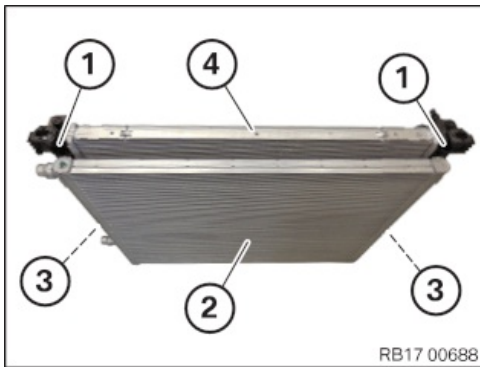

- Guide radiator of low-temperature coolant circuit (2) into the guides (3) of the radiator of the high-temperature coolant circuit (4) and install.
- The locks (1) must engage audibly.



- Guide in and install cover (1).

11 – Install the radiator of the high-temperature coolant circuit



TECHNICAL INFORMATION

Notes on work at the cooling system form the basis of these repair instructions and must be complied with at all times.
For additional information see: 17 00 ... Instructions for repair work on cooling system



TECHNICAL INFORMATION

Make sure that the connections are locked correctly. The locks must engage audibly.



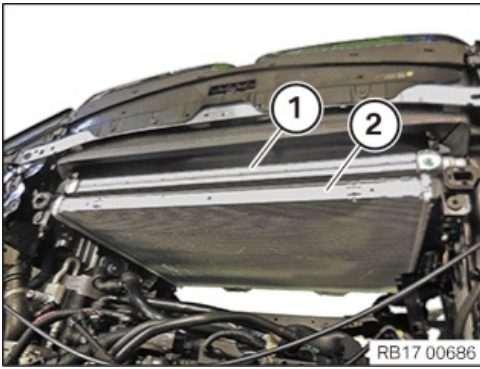

- Guide in radiator of low-temperature coolant circuit (1) with radiator of high-temperature coolant circuit (2) and install.

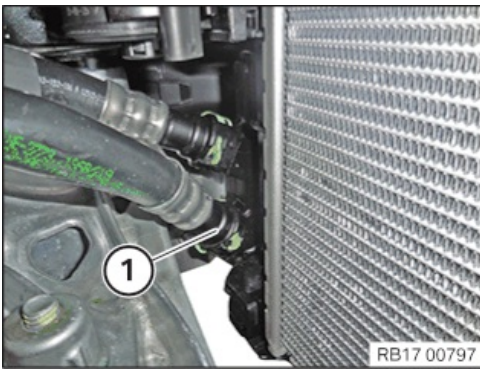

- Connect the transmission oil feed line (1) to the transmission oil cooler and lock.

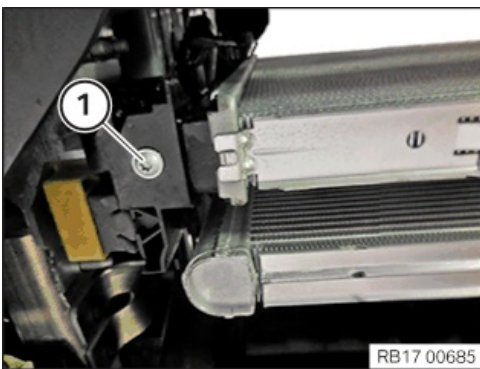

- Tighten screw (1) on bottom cooling module, left.

Radiator to cooling module, bottom

| | | | |
|--------|--|-------------------|------|
| TS6x20 | | Tightening torque | 6 Nm |
|--------|--|-------------------|------|

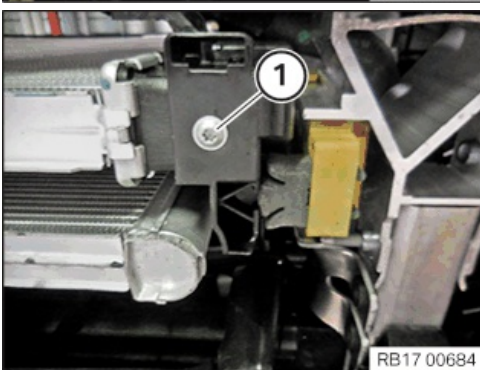

- Tighten screw (1) on bottom cooling module, right.

Radiator to cooling module, bottom

| | | | |
|--------|--|-------------------|------|
| TS6x20 | | Tightening torque | 6 Nm |
|--------|--|-------------------|------|

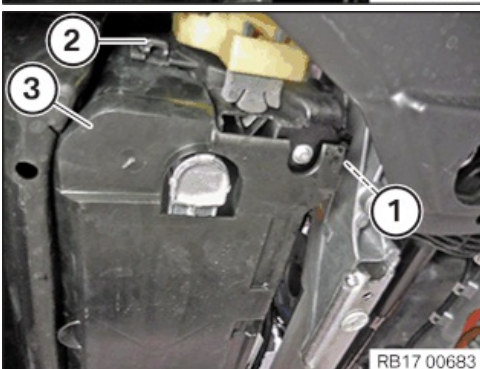

- Insert and install the cover (3) at the bottom left cooling module.
- Ensure that the lock (2) engages audibly.
- Ensure that the lock (1) engages audibly.



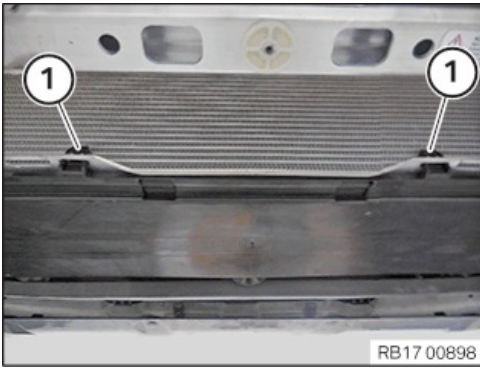

- Ensure that the locks (1) engage audibly.

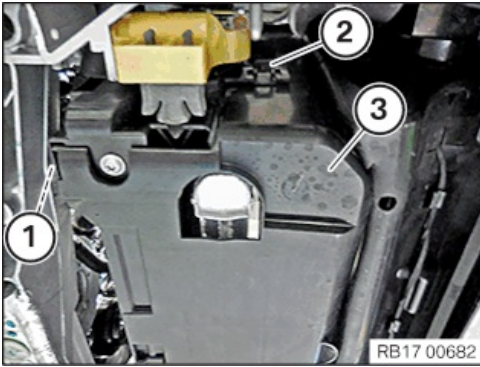

- Feed in and install cover (3) on cooling module, bottom right.
- Ensure that the lock (2) engages audibly.
- Ensure that the lock (1) engages audibly.



- Connect and lock coolant line (1).
- Make sure that the coolant line (1) engages audibly.

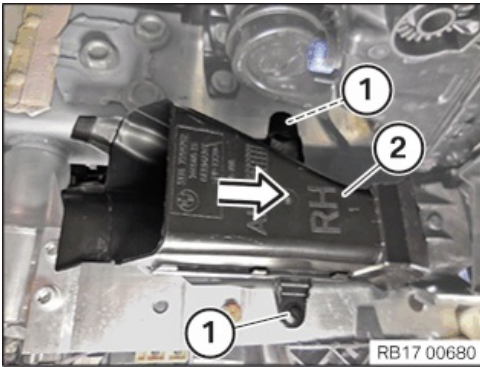

- Feed in air duct (2) in direction of arrow and install.
- Secure clamps (1).

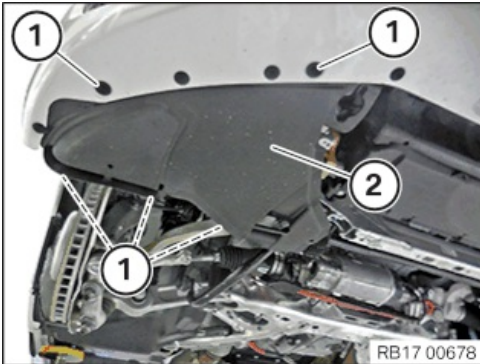

- Guide in and install cover (2), front right.
- Secure the clamps.
- Tighten the screws (1).

Cover to front bumper

| Screw | Tightening torque | 3 Nm |
|-------|-------------------|------|
|-------|-------------------|------|



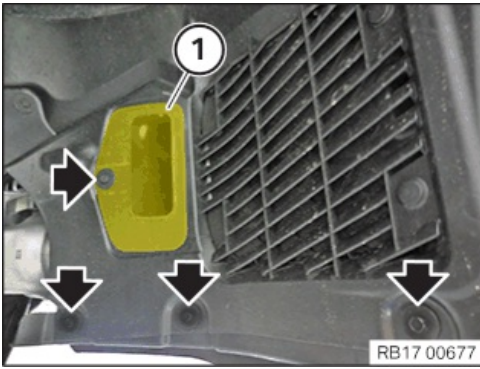

- Thread in air duct (1) and install.
- Tighten screws (arrows).

Cover to front bumper

| Screw | Tightening torque |
|-------|-------------------|
| | 3 Nm |

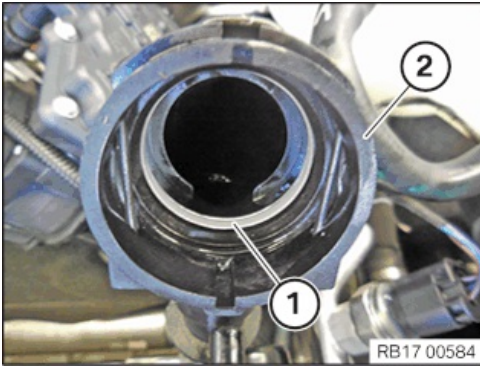

- Check the sealing rings (1) of the coolant lines (2) for damage and renew if necessary.

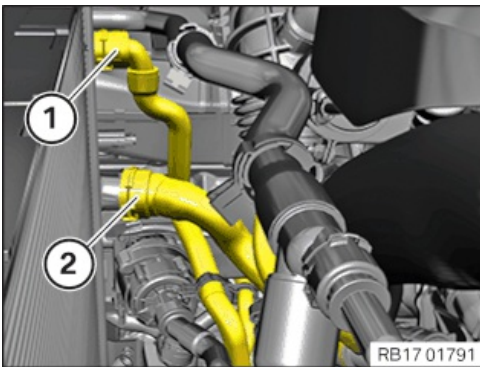

- Connect and lock coolant line (1).
The coolant line (1) must engage audibly.
- **Version with external radiator:**
Connect and lock the coolant line (2).
The coolant line (2) must audibly engage.

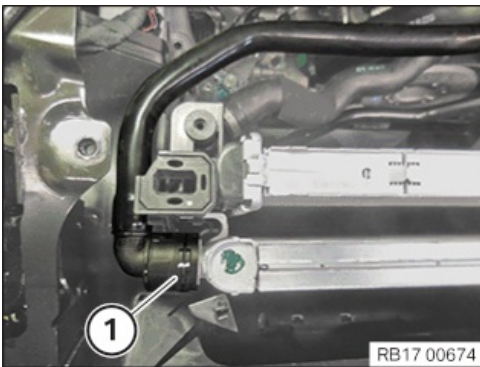

- Connect and lock coolant line (1).
- Make sure that the cooling line (1) engages audibly.

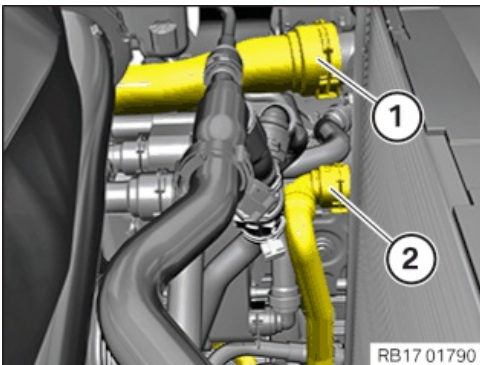

- Connect and lock coolant line (1).
The coolant line (1) must engage audibly.
- **Version with external radiator:**
Connect and lock the coolant line (2).
The coolant line (2) must audibly engage.





- Guide in and install cover (3) on cooling module at the top.
- Ensure that the locks (2) engage audibly.
- Ensure that the locks (1) engage audibly.

RB17 00672

POSTPROCESSES

12 – Install fan cowl

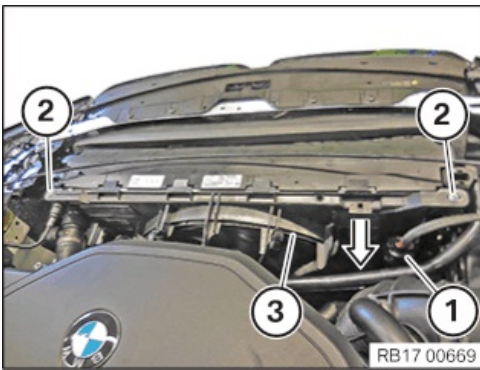

- Feed in and install the fan cowl (3) in the direction of the arrow.
- Tighten the screws (2).

Fan cowl on radiator

TS6x20

6 Nm

- Connect and lock the connector (1).
The connector (1) must engage audibly.

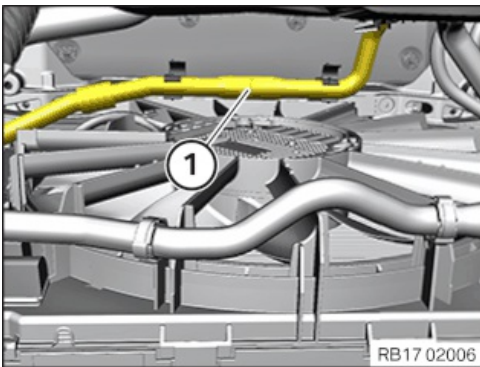

- **If fitted:**
Fasten the coolant line (1) below at the fan cowl with the clamps.

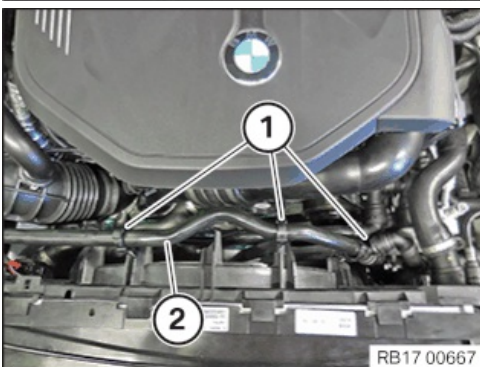

- Feed in and install coolant line (2).
- Lock clamps (1).
The clamps (1) must engage audibly.

13 – Install the rear top cross connection



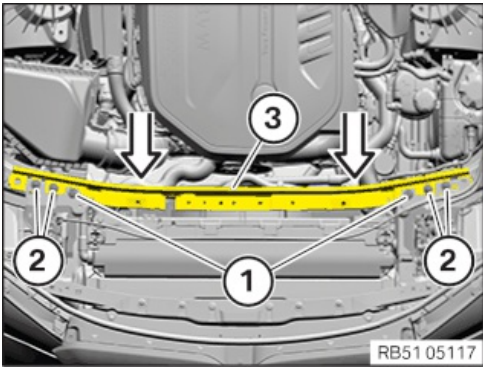

- Guide the cross connection (3) in from the rear in the direction of arrow.
- Tighten down screws (1) and (2).

Top rear cross connection

| | | | |
|------------------------|--|-------------------|-------|
| Torx screw M8x30 | | Tightening torque | 19 Nm |
| Hexagon screw M8x20 | | Tightening torque | 19 Nm |

14 – Install front cross connection

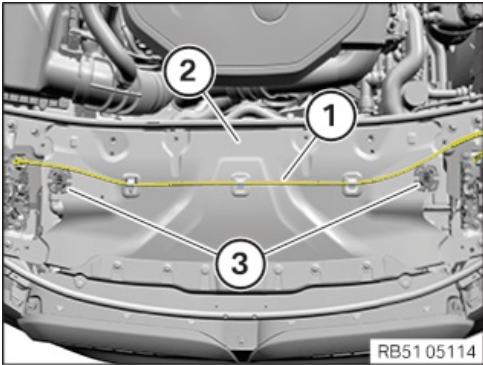

- Feed in cross connection (2) with brackets (3).
- Attach the Bowden cable (1).

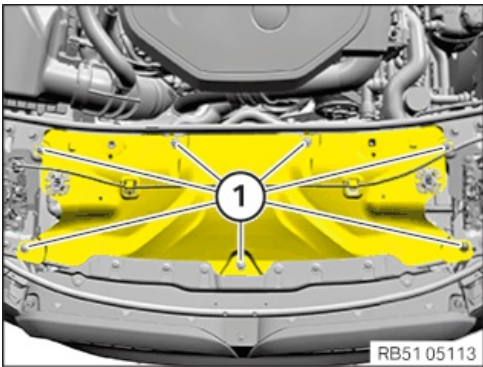

- Tighten the screws (1).

Front cross connection

| | | | |
|-------|--|-------------------|---------|
| Screw | | Tightening torque | 11,8 Nm |
|-------|--|-------------------|---------|

15 – Installing both front-end struts



NOTICE

Description is for right component only. The procedure on the left side is identical.

► Installing the front-end strut



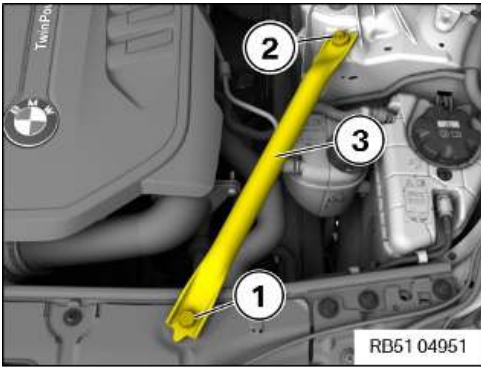

- Install the front-end strut (3).



RISK OF DAMAGE

Use of an incorrect tool (impact screwdriver) to release and tighten the screws.

Damaged thread.

- Only use a standard tool (e.g. reversible ratchet) to release/tighten the screw.

- Clean threads on spring strut dome.
- Renew the screw (1).

Parts: Screw

- Tighten down screw (1).

Front-end strut to cross connection

| | | | |
|---------------|--------------|-------------------|-------|
| Hexagon screw | Renew screw. | Jointing torque | 28 Nm |
| | | Angle of rotation | 90 ° |

- Renew the screw (2).

Parts: Screw

- Tighten down screw (2).

Front end strut

| | | | |
|-------|--------------|-------------------|-------|
| Screw | Renew screw. | Jointing torque | 56 Nm |
| | | Angle of rotation | 90 ° |

- Repair damaged threads on the spring strut dome with a Helicoil insert.

Expendable materials

| | | |
|------------------------|-----------|-------------|
| Helicoil thread insert | M10x30 mm | 07129909659 |
|------------------------|-----------|-------------|

16 – Installing the cover on the left and right in the top engine compartment



NOTICE

Description is for left component only. Procedure on the right side is identical.

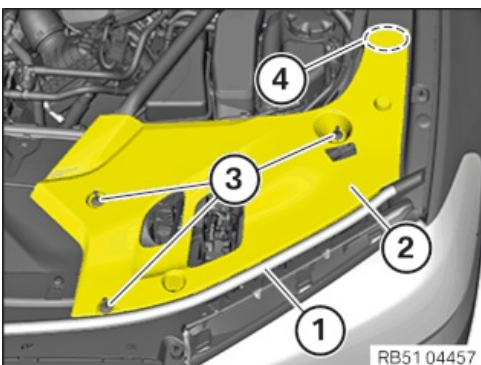

► Install the cover in the engine compartment on top

- Insert the cover (2) in the area (4).
- Secure expanding rivet (3).
- Mount seal (1) on cover (2).

17 – Filling and bleed the high-temperature coolant circuit





TECHNICAL INFORMATION

It is **mandatory** to fill the cooling system before bleeding.
Fill **both** the circuits for high and low-temperature coolant circuits.

- See additional information.

18 – Filling and bleed the low-temperature coolant circuit



TECHNICAL INFORMATION

It is **mandatory** to fill the cooling system before bleeding.
Fill **both** the circuits for high and low-temperature coolant circuits.

- See additional information.

19 – Checking/topping up oil level in automatic transmission

Prerequisite

Vehicle is in a horizontal position.

The vehicle is secured against rolling away.



CAUTION

Materials harmful to health.

Contact with fluids harmful to health!

- Note and follow safety information on containers.
- Conduct all work in appropriate personal protective equipment only.



TECHNICAL INFORMATION

To set the correct oil level, it is mandatory that the service function "Transmission control unit: Oil-level adjustment" is carried out with the diagnosis system.



TECHNICAL INFORMATION

Carry out oil-level adjustment:

Certain fault memory entries may require an oil-level adjustment in the automatic transmission and after repairs have been completed (e.g. exchange of mechatronics, exchange of the converter, exchange of the transmission, automatic transmission oil service).





TECHNICAL INFORMATION

The automatic transmission fluid specified by BMW must be used for the automatic transmission.

For additional information see: SBS-ANL-SBS1996-240596143_A14 (automatic transmission fluid for ZF transmissions, etc.)

- Connect diagnosis system.
- Observe the predefined transmission oil temperatures for the oil-level adjustment with the diagnosis system:
 - Initial condition: Transmission oil temperature 30°C to 40°C.
 - Final condition: Transmission oil temperature 40°C to 50°C.
- Call up service function (drive).
- Carry out oil-level adjustment in accordance with the instructions.
- Loosen the oil filler plug (1) using the special tool [2 405 614](#).
- Top up automatic transmission fluid according to the instructions in the diagnosis system.

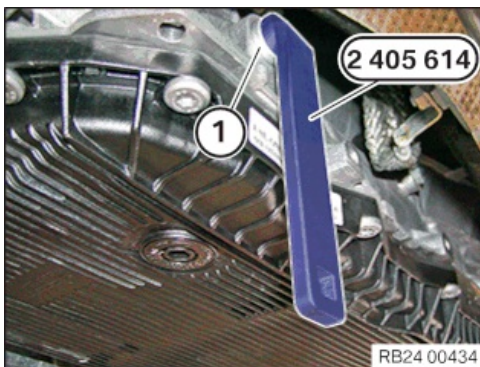

GA8HP51Z transmission capacity

min. 9,28 l

Transmission oil: Automatic transmission fluid ATF 3+

GA8HP76Z transmission capacity

min. 9,35 l

Transmission oil: Automatic transmission fluid ATF 3+

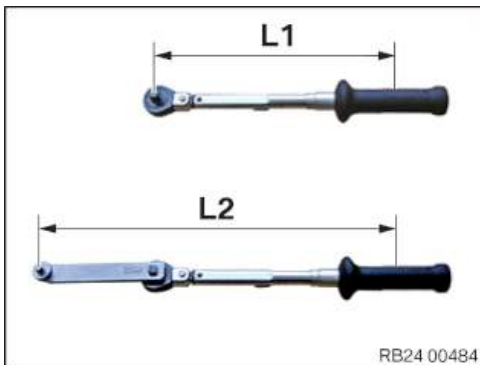

TECHNICAL INFORMATION

The setpoint torque deviates from the torque to be set when using special tool 2 405 614.

- Converting the setpoint torque into the torque to be set:
(setpoint torque x L1) : L2 = Torque to be set
L1 = Length from the centre of the handle to the reversible ratchet head
L2 = Length from the centre of the handle to the engaging of the special tool in the bolt
 - Renew the oil filler plug (1) and the sealing ring.
- Parts:** Oil filler plug, sealing ring
- Make sure that the special tool [2 405 614](#) and the torque wrench (2) align while tightening the oil filler plug (1).
 - Tighten the oil filler plug (1) with the special tool [2 405 614](#) and the torque wrench (2).

Oil filler plug

M18x1.5

Tightening torque

35 Nm

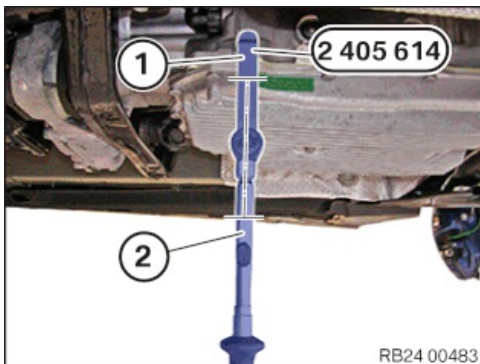



TECHNICAL INFORMATION

Different variants may be installed depending on the vehicle equipment.

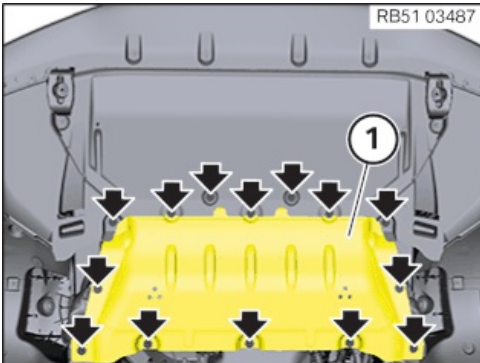

- **Version A:**

Insert steering gear aggregate protective plate (1).

Tighten screws (arrows).

Underbody protection

| | | | |
|-------|--|-------------------|------|
| Screw | | Tightening torque | 3 Nm |
|-------|--|-------------------|------|

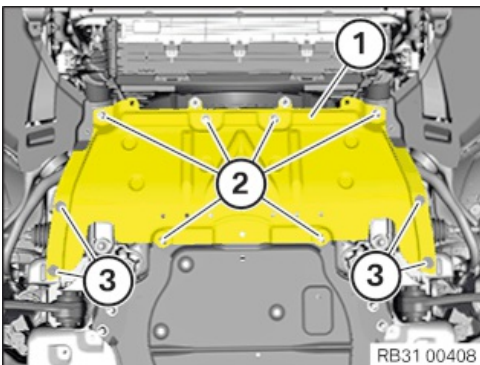

- **Version B:**

Renew screws (2).

Parts: Screws

Position the front stiffening plate (1).

Tighten the screws (2).

Stiffening plate to front axle support

| | | | |
|----|---------------|-------------------|-------|
| M8 | Renew screws. | Jointing torque | 25 Nm |
| | | Angle of rotation | 70 ° |

- Tighten the screws (3).

Cover, steering unit

| | | | |
|-------|--|-------------------|------|
| Screw | | Tightening torque | 3 Nm |
|-------|--|-------------------|------|

21 – Install front underbody protection and/or front stiffening plate



TECHNICAL INFORMATION

Different variants may be installed depending on the vehicle equipment.

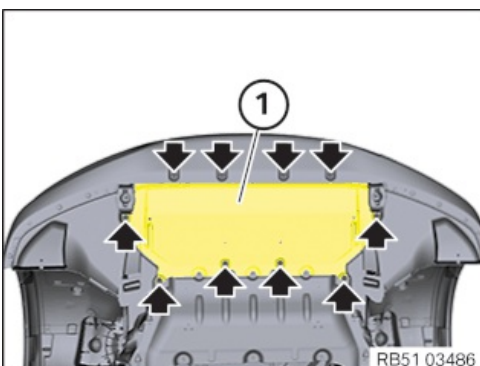

- **Version A:**

Insert the front underbody protection (1).

Tighten screws (arrows).

Underbody protection

| | | | |
|-------|--|-------------------|------|
| Screw | | Tightening torque | 3 Nm |
|-------|--|-------------------|------|



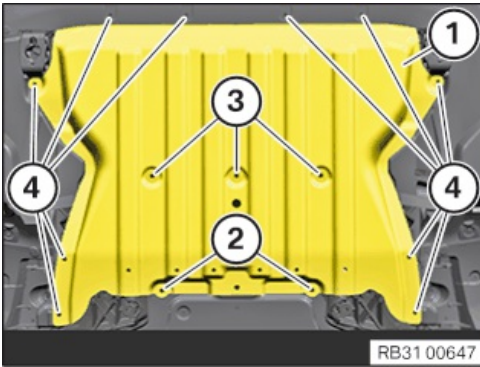

• **Version B:**

Position the front stiffening plate (1).

Renew screws (2).

Parts: Screws

Tighten the screws (2).

Stiffening plate to front axle support

| | | | |
|----|---------------|-------------------|-------|
| M8 | Renew screws. | Jointing torque | 25 Nm |
| | | Angle of rotation | 70 ° |

• Tighten the screws (3).

• Tighten the screws (4).

Underbody protection

| | | | |
|-------|--|-------------------|------|
| Screw | | Tightening torque | 3 Nm |
|-------|--|-------------------|------|

22 – Installing underbody protection at rear



NOTICE

To provide a better overview: Schematic diagram with partially hidden components.

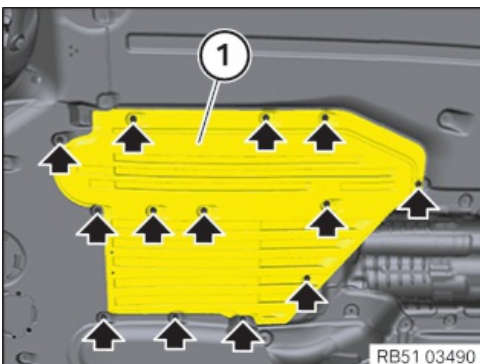

• **Version A:**

Insert the rear underbody protection (1).

Tighten screws (arrows).

Underbody panelling

| | | | |
|-------------|--|-------------------|--------|
| Screw | | Tightening torque | 2,6 Nm |
| Plastic nut | | Tightening torque | 2,6 Nm |

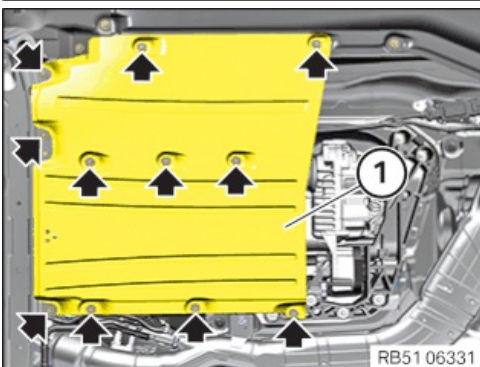

• **Version B:**

Insert and install the rear underbody protection (1).

Tighten screws (arrows).

Underbody panelling

| | | | |
|-------------|--|-------------------|--------|
| Screw | | Tightening torque | 2,6 Nm |
| Plastic nut | | Tightening torque | 2,6 Nm |

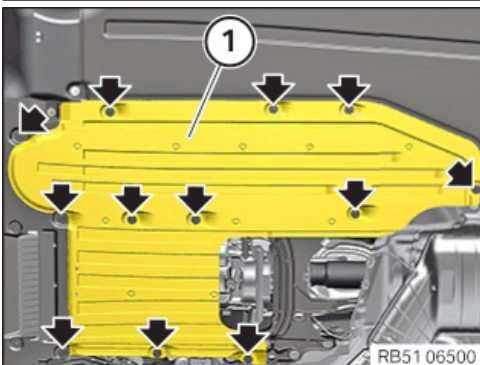

• **Version C:**

Insert and install the rear underbody protection (1).

Tighten screws (arrows).

Underbody panelling

| | | | |
|-------------|--|-------------------|--------|
| Screw | | Tightening torque | 2,6 Nm |
| Plastic nut | | Tightening torque | 2,6 Nm |



Additional Information

Overview of Tightening Torques

| | | | |
|---|---------------|-------------------|-------------------|
| Radiator to cooling module, bottom | | | Used in step 11 |
| TS6x20 | | Tightening torque | 6 Nm |
| Cover to front bumper | | | Used in step 11 |
| Screw | | Tightening torque | 3 Nm |
| Fan cowl on radiator | | | Used in step 12 |
| TS6x20 | | | 6 Nm |
| Top rear cross connection | | | Used in step 13 |
| Torx screw M8x30 | | Tightening torque | 19 Nm |
| Hexagon screw M8x20 | | Tightening torque | 19 Nm |
| Front cross connection | | | Used in step 14 |
| Screw | | Tightening torque | 11,8 Nm |
| Front-end strut to cross connection | | | Used in step 15 |
| Hexagon screw | Renew screw. | Jointing torque | 28 Nm |
| | | Angle of rotation | 90 ° |
| Front end strut | | | Used in step 15 |
| Screw | Renew screw. | Jointing torque | 56 Nm |
| | | Angle of rotation | 90 ° |
| Oil filler plug | | | Used in step 19 |
| M18x1.5 | | Tightening torque | 35 Nm |
| Underbody protection | | | Used in step 2021 |
| Screw | | Tightening torque | 3 Nm |
| Stiffening plate to front axle support | | | Used in step 2021 |
| M8 | Renew screws. | Jointing torque | 25 Nm |
| | | Angle of rotation | 70 ° |
| Cover, steering unit | | | Used in step 20 |
| Screw | | Tightening torque | 3 Nm |
| Underbody panelling | | | Used in step 22 |
| Screw | | Tightening torque | 2,6 Nm |
| Plastic nut | | Tightening torque | 2,6 Nm |

Overview of Special Tools



2 405 614 Socket wrench



Common

Used in step 19

Usage

For opening and closing the oil filler plug. Contour-graphic silhouette foil is included in delivery specification. Further information on the contour-graphic silhouette foil can be found in service information 00 22 13 (969). Replaced by 2455997

Included in the tool or work

Storage location

Replaced by

In connection with

SI-Number 01 33 15 (305)

Overview Technical Data

GA8HP51Z transmission capacity

Used in step 19

min. 9,28 l

Transmission oil: Automatic transmission fluid ATF 3+

GA8HP76Z transmission capacity

Used in step 19

min. 9,35 l

Transmission oil: Automatic transmission fluid ATF 3+

Links

Repair instructions

Used in step

| | |
|--|-----|
| 17 00 ... Instructions for repair work on cooling system | 911 |
| 17 00 008 Draining and topping up coolant for high-temperature circuit | 17 |
| 17 00 039 Bleed the cooling system and check it for watertightness with the special tool | 17 |
| 17 00 039 Bleed the cooling system and check it for watertightness with the special tool | 17 |
| 17 00 039 Bleed the cooling system and check it for watertightness with the special tool | 17 |
| 17 00 008 Draining and topping up coolant for high-temperature circuit | 17 |
| 17 00 008 Draining and topping up coolant for high-temperature circuit | 17 |
| 17 00 008 Draining and topping up coolant for high-temperature circuit | 17 |
| 17 00 008 Draining and topping up coolant for high-temperature circuit | 17 |
| 17 00 039 Bleed the cooling system and check it for watertightness with the special tool | 17 |
| 17 00 039 Bleed the cooling system and check it for watertightness with the special tool | 17 |
| 17 00 039 Bleed the cooling system and check it for watertightness with the special tool | 17 |
| 17 00 039 Bleed the cooling system and check it for watertightness with the special tool | 17 |
| 17 00 039 Bleed the cooling system and check it for watertightness with the special tool | 17 |



| | |
|---|------|
| 17 00 039 Bleed the cooling system and check it for watertightness with the special tool | 17 |
| 17 00 039 Bleed the cooling system and check it for watertightness with the special tool | 17 |
| 17 00 039 Bleed the cooling system and check it for watertightness with the special tool | 17 |
| 17 00 039 Bleed the cooling system and check it for watertightness with the special tool | 17 |
| 17 00 040 Bleed the cooling system and check for watertightness with the special tool (coolant circuit for low temperature) | 1718 |
| 17 00 039 Bleed the cooling system and check it for watertightness with the special tool | 17 |
| 17 00 009 Check the cooling system for watertightness with a special tool (with a tester) | 17 |
| 17 00 009 Check the cooling system for watertightness with a special tool (with a tester) | 17 |
| 17 00 039 Bleed the cooling system and check it for watertightness with the special tool | 17 |
| 17 00 008 Draining and topping up coolant for high-temperature circuit | 17 |
| 17 00 039 Bleed the cooling system and check it for watertightness with the special tool | 17 |
| 17 00 039 Bleed the cooling system and check it for watertightness with the special tool | 17 |
| 17 00 008 Draining and topping up coolant for high-temperature circuit | 17 |
| 17 00 039 Bleed the cooling system and check it for watertightness with the special tool | 17 |
| 17 00 039 Bleed the cooling system and check it for watertightness with the special tool | 17 |
| 17 00 039 Bleed the cooling system and check it for watertightness with the special tool | 17 |
| 17 00 011 Draining and topping up the coolant for the low-temperature circuit | 18 |
| 17 00 040 Bleed the cooling system and check for watertightness with the special tool (coolant circuit for low temperature) | 18 |
| 17 00 040 Bleed the cooling system and check for watertightness with the special tool (coolant circuit for low temperature) | 18 |
| 17 11 103 Removing and installing/replacing coolant expansion tank for the low-temperature coolant circuit | 18 |
| 17 11 103 Removing and installing/replacing coolant expansion tank for the low-temperature coolant circuit | 18 |
| 17 00 040 Bleed the cooling system and check for watertightness with the special tool (coolant circuit for low temperature) | 18 |
| 17 00 040 Bleed the cooling system and check for watertightness with the special tool (coolant circuit for low temperature) | 18 |
| 17 00 040 Bleed the cooling system and check for watertightness with the special tool (coolant circuit for low temperature) | 18 |
| 17 00 040 Venting cooling system and checking on watertightness | 18 |
| 17 00 040 Venting high temperature - cooling system and checking for water leaks (N20 hybrid drive) | 18 |
| 17 00 040 Venting high temperature - cooling system and checking for water leaks (N20 hybrid drive) | 18 |
| 17 00 040 Bleeding lower-temperature cooling system (B48) | 18 |
| 17 00 040 Bleed the cooling system and check for watertightness with the special tool (coolant circuit for low temperature) | 18 |
| 17 00 040 Bleed the cooling system and check for watertightness with the special tool (coolant circuit for low temperature) | 18 |
| 17 00 040 Bleed the cooling system and check for watertightness with the special tool (coolant circuit for low temperature) | 18 |
| 17 00 040 Bleed the cooling system and check for watertightness with the special tool (coolant circuit for low temperature) | 18 |
| 17 00 040 Bleed the cooling system and check for watertightness with the special tool (coolant circuit for low temperature) | 18 |
| 17 00 011 Draining and topping up coolant circuit for low temperature | 18 |
| 17 00 040 Bleed the low-temperature cooling system and check for watertightness (coolant circuit for low temperature) | 18 |
| 17 00 040 Bleeding and filling low temperature cooling system using vacuum filler device (B48) | 18 |



| | |
|---|----|
| 17 00 011 Draining and topping up low-temperature coolant circuit | 18 |
| 17 00 011 Draining and topping up low-temperature coolant circuit | 18 |
| 17 00 040 Bleeding the low-temperature coolant circuit and checking it for watertightness | 18 |
| 17 00 040 Bleeding the low-temperature coolant circuit and checking it for watertightness | 18 |
| 17 00 015 Draining and topping up the coolant circuit for the drive IPREMIUM | 18 |
| 17 00 011 Draining and topping up low-temperature coolant circuit | 18 |
| 17 00 040 Bleed the cooling system and check for watertightness with the special tool (low-temperature coolant circuit) | 18 |
| 17 00 040 Bleed the cooling system and check for watertightness with the special tool (coolant circuit for low temperature) | 18 |
| 17 00 040 Bleed the cooling system and check for watertightness with the special tool (coolant circuit for low temperature) | 18 |
| 17 00 040 Bleed the cooling system and check for watertightness with the special tool (coolant circuit for low temperature) | 18 |
| 17 00 040 Bleed the cooling system and check for watertightness with the special tool (coolant circuit for low temperature) | 18 |
| 17 00 040 Bleed the cooling system and check for watertightness with the special tool (coolant circuit for low temperature) | 18 |
| 17 00 040 Bleed the cooling system and check for watertightness with the special tool (coolant circuit for low temperature) | 18 |
| 17 00 040 Bleed the cooling system and check for watertightness with the special tool (coolant circuit for low temperature) | 18 |
| 17 00 040 Bleed the cooling system and check for watertightness with the special tool (coolant circuit for low temperature) | 18 |
| 17 00 040 Bleed the cooling system and check for watertightness with the special tool (coolant circuit for low temperature) | 18 |
| 17 00 040 Bleed the cooling system and check for watertightness with the special tool (coolant circuit for low temperature) | 18 |
| 17 00 040 Bleed the cooling system and check for watertightness with the special tool (coolant circuit for low temperature) | 18 |
| 17 00 040 Bleed the cooling system and check for watertightness with the special tool (coolant circuit for low temperature) | 18 |

| Operating materials | Used in step |
|--|---------------------|
| 14.0 Automatic transmission fluid for ZF-transmission GA8HP45Z / GA8HP50Z / GA8HP70Z / GA8HP90Z / GA8P70H / GA8P75H / GA8HP75Z | 19 |

| Operating materials | Used in step |
|----------------------------|---------------------|
| Main group 17 | 9 |



17 11 000 Removing and installing coolant radiator



WARNING

Hot surfaces.

Risk of burning!

- Perform all work only on components that have cooled down.

PRELIMINARY WORK

1 – Removing the cover on the left and right in the top engine compartment



NOTICE

Description is for left component only. Procedure on the right side is identical.

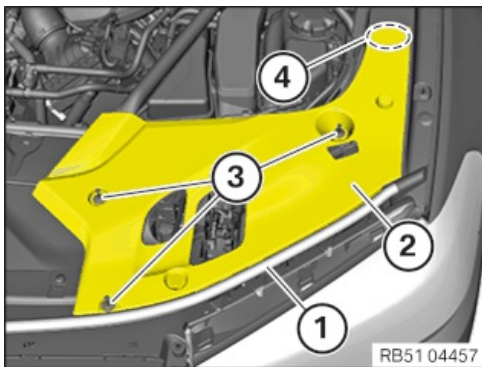

► Remove the cover in the engine compartment on top

- Detach the gasket (1) in the area of the cover (2).
- Loosen the expanding rivet (3).
- Guide out and remove the cover (2) in the area (4).

2 – Removing left and right front-end strut



NOTICE

Description is for left component only. Procedure on the right side is identical.

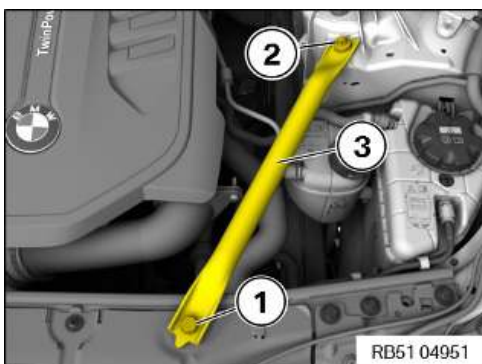

► Removing the front-end strut



RISK OF DAMAGE

Use of an incorrect tool (impact screwdriver) to release and tighten the screws.

Damaged thread.

- Only use a standard tool (e.g. reversible ratchet) to release/tighten the screw.
- Loosen screws (1) and (2).
- Remove the front-end strut (3).



3 – Remove front cross connection

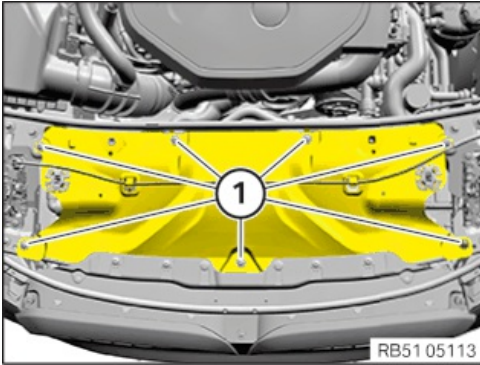

- Loosen screws (1).

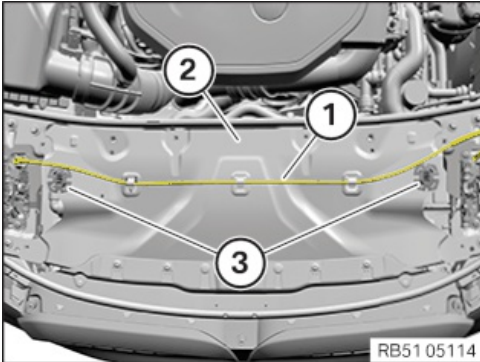

- Detach the Bowden cable (1).
- Feed out cross connection (2) with brackets (3) and remove.

4 – Remove the rear top cross connection

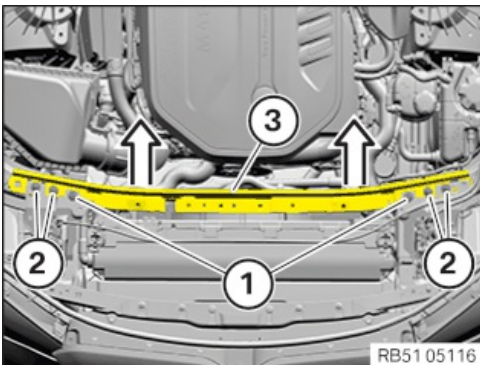

- Loosen screws (1) and (2).
- Guide the cross connection (3) out in the direction of the arrow.

5 – Removing the fan cowl



WARNING

Hot surfaces.

Risk of burning!

- Perform all work only on components that have cooled down.





- Unlock and loosen the clamps (1).
- Feed out coolant line (2) and place to one side.

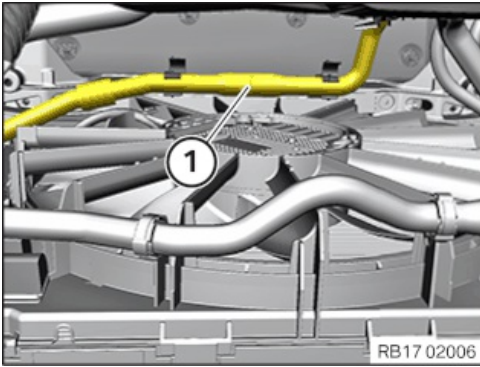

- **If fitted:**
Release the coolant line (1) below at the fan cowl from the clamps and place it to the side.

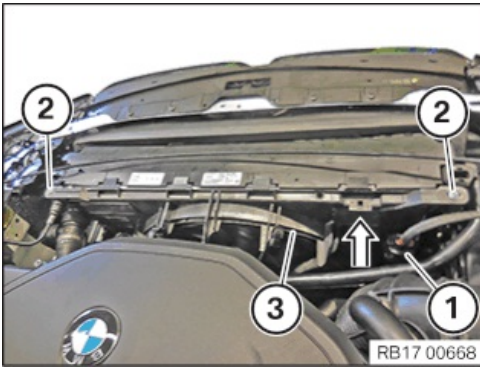

- Unlock and loosen connector (1).
- Loosen screws (2).
- Guide out fan cowl (3) in direction of arrow and remove.

6 – Remove front underbody protection and/or front stiffening plate



TECHNICAL INFORMATION

Different variants may be installed depending on the vehicle equipment.

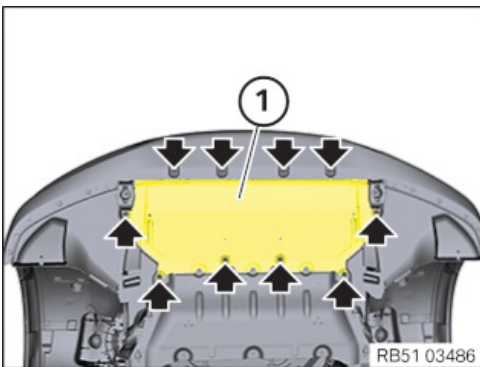

- **Version A:**
Remove screws (arrows).
Feed out the front underbody protection (1).



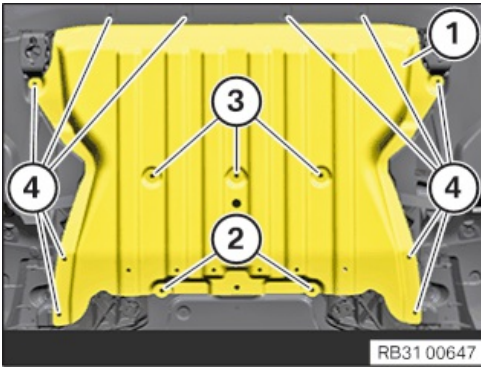

TECHNICAL INFORMATION

Driving without stiffening plate is not permissible.

- **Version B:**
Loosen screws (2) to (4).
Remove the front stiffening plate (1).

7 – Removing the underbody protection of the steering gear and front stiffening plate respectively



TECHNICAL INFORMATION

Different variants may be installed depending on the vehicle equipment.

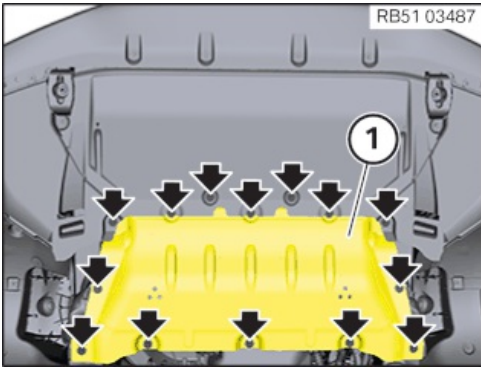

- **Version A:**
Release all bolts (arrows).
Guide out underbody protection (1) of the steering gear.

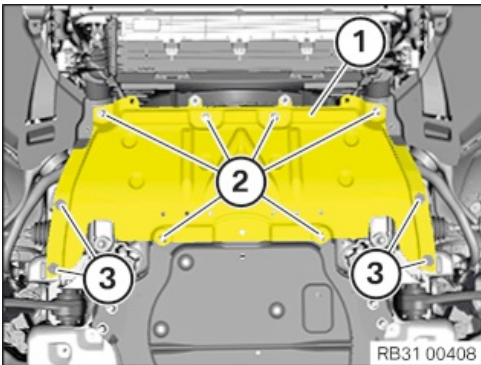

TECHNICAL INFORMATION

Driving without stiffening plate is not permissible.

- **Version B:**
Loosen screws (3).
Loosen screws (2).
Remove front stiffening plate (1).

MAIN WORK

8 – Remove the radiator of the high-temperature coolant circuit



WARNING

Hot surfaces.

Risk of burning!

- Perform all work only on components that have cooled down.





CAUTION

Materials harmful to health.

Contact with fluids harmful to health!

- Note and follow safety information on containers.
- Conduct all work in appropriate personal protective equipment only.



TECHNICAL INFORMATION

Life-long fill of coolant!

Do not reuse used coolant.

When replacing and removing components which rely on the corrosion protection effect of the coolant, it is essential to change the coolant. The cooling system must therefore be emptied and refilled.

In the case of other removal work involving the draining of part quantities of coolant, the coolant level must be topped up with new coolant.



TECHNICAL INFORMATION

Follow notes for repair work on the cooling system.

For additional information see:

Main group 17

17 00 ... Notes for working on the cooling system



TECHNICAL INFORMATION

Collect and dispose of emerging fluids. Observe country-specific waste disposal regulations.

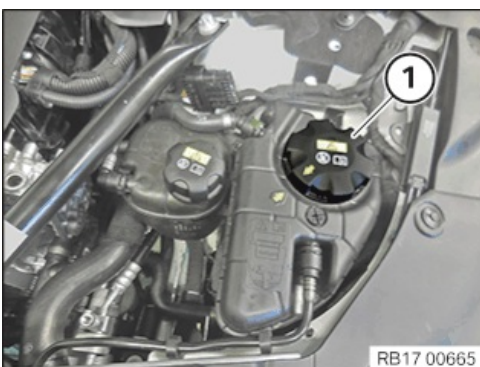

- Loosen sealing cap (1).

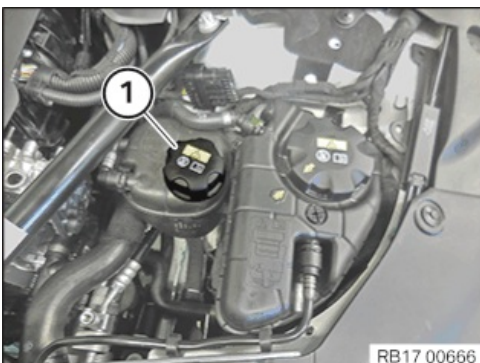

- Loosen sealing cap (1).





- Unlock the locks (1).
- Unlock the locks (2).
- Remove the cover (3) of the top cooling module.

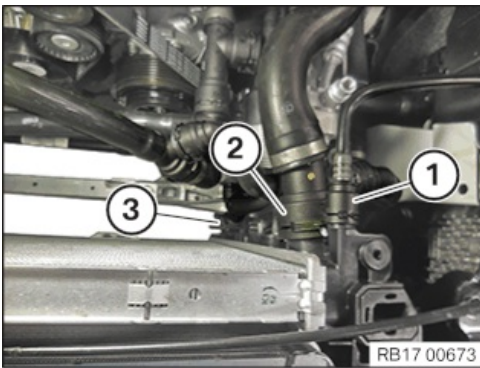

- **If fitted:**
Unlock and loosen coolant line (1).
- Unlock and loosen coolant line (2).
- **If fitted:**
Unlock and loosen coolant line (3).
- Catch and dispose of escaping coolant.

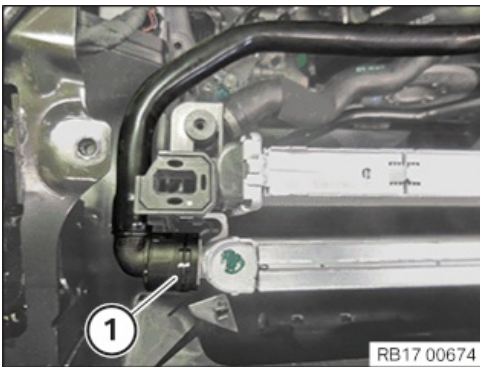

- Unlock and loosen coolant line (1).
- Catch and dispose of escaping coolant.

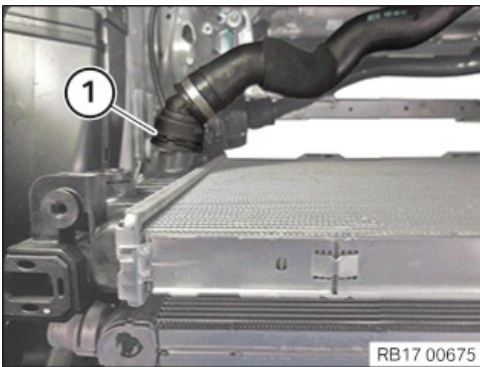

- Unlock and loosen coolant line (1).
- Catch and dispose of escaping coolant.

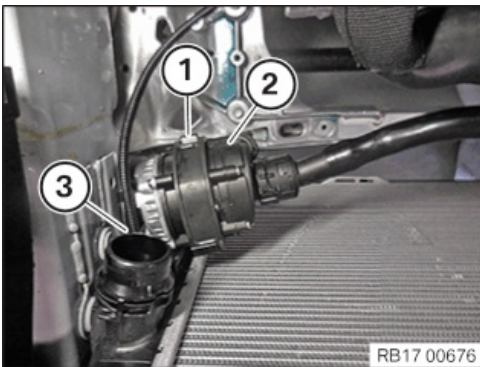

- Loosen the holder (1).
- Remove the electric coolant pump (2) and put to one side.
- Loosen clamp (3).



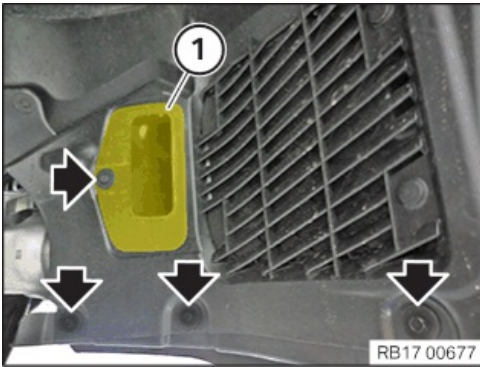

- Remove screws (arrows).
- Thread out air duct (1) and remove.

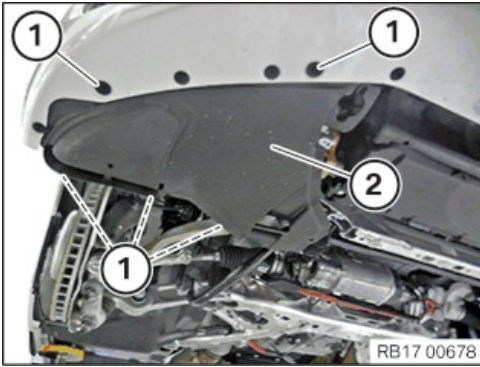

- Loosen clamps .
- Loosen screws (1).
- Guide out and remove the cover (2).

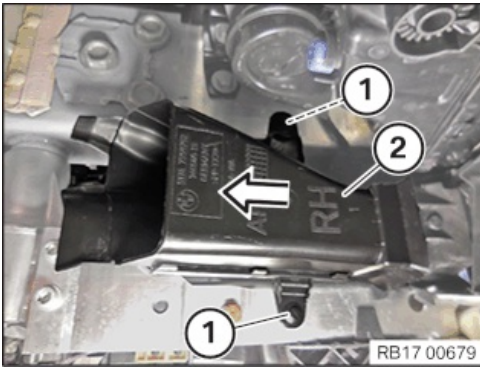

- Loosen clamps (1).
- Guide out air duct (2) in direction of arrow and remove.



- Unlock and loosen coolant line (1).
- Catch and dispose of escaping coolant.

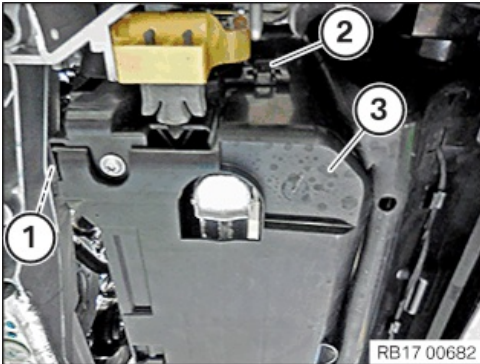

- Unlock lock (1).
- Unlock lock (2).
- Release the cover (3) of the cooling module at the bottom.



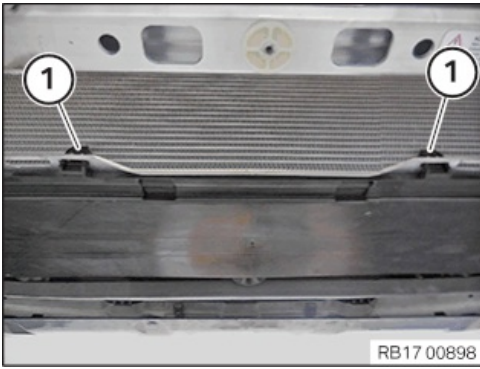

- Unlock the locks (1).

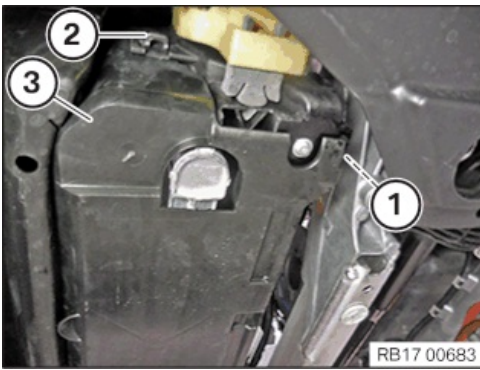

- Unlock lock (1).
- Unlock lock (2).
- Remove the cover (3) of the bottom cooling module.

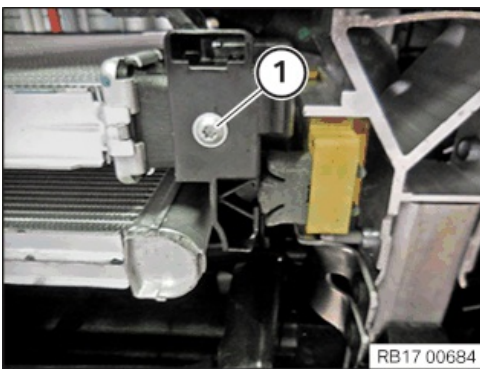

- Loosen screw (1).

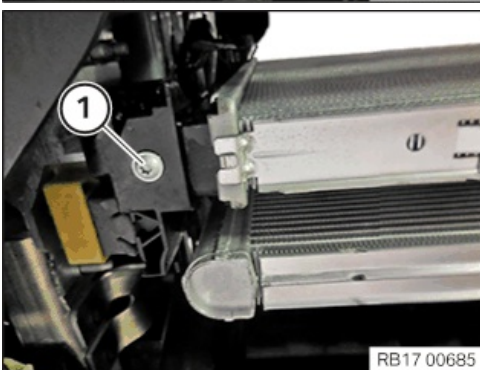

- Loosen screw (1).

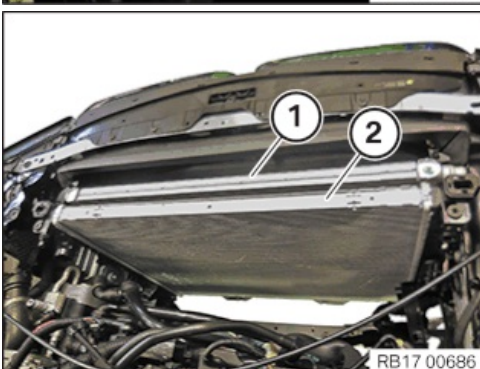

- Remove the radiator of the low-temperature coolant circuit (1) including the radiator of the high-temperature coolant circuit (2).

9 – Renewing the radiator of the high-temperature coolant circuit





- Unlock and loosen the covers (1).

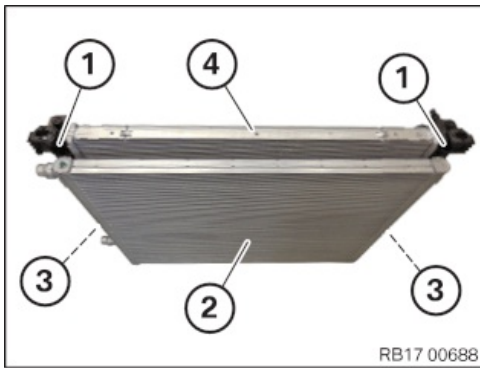

- Unlock the locks (1).
- Guide radiator of low-temperature coolant circuit (2) out of the guides (3) of the radiator of the high-temperature coolant circuit (4) and remove.
- Renew high temperature radiator (4).

Parts: Radiator of high-temperature coolant circuit (4)

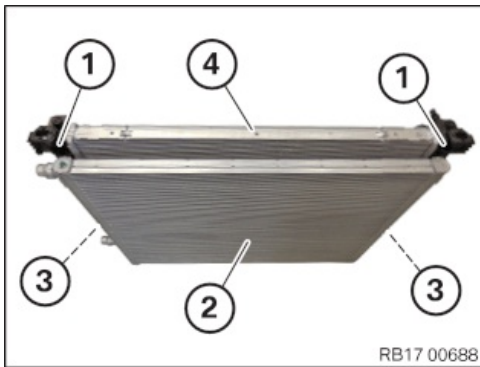

- Guide radiator of low-temperature coolant circuit (2) into the guides (3) of the radiator of the high-temperature coolant circuit (4) and install.

The locks (1) must engage audibly.



- Guide in and install cover (1).

10 – Install the radiator of the high-temperature coolant circuit



TECHNICAL INFORMATION

Notes on work at the cooling system form the basis of these repair instructions and must be complied with at all times.
For additional information see: 17 00 ... Instructions for repair work on cooling system



TECHNICAL INFORMATION

Make sure that the connections are locked correctly. The locks must engage audibly.



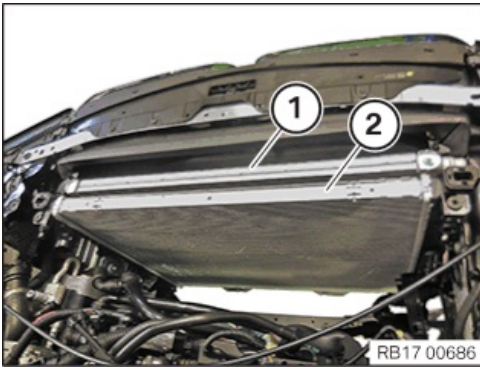

- Guide in radiator of low-temperature coolant circuit (1) with radiator of high-temperature coolant circuit (2) and install.

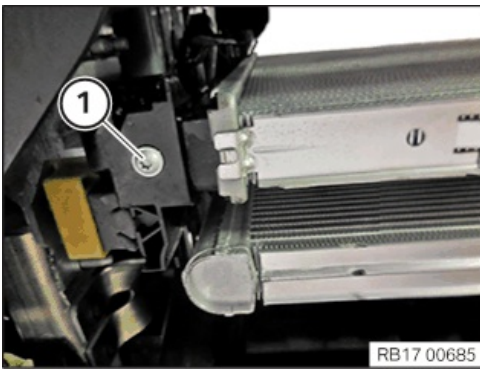

- Tighten screw (1) on bottom cooling module, left.

Radiator to cooling module, bottom

| | | | |
|--------|--|-------------------|------|
| TS6x20 | | Tightening torque | 6 Nm |
|--------|--|-------------------|------|

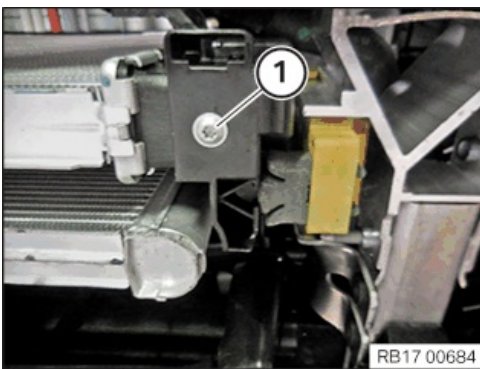

- Tighten screw (1) on bottom cooling module, right.

Radiator to cooling module, bottom

| | | | |
|--------|--|-------------------|------|
| TS6x20 | | Tightening torque | 6 Nm |
|--------|--|-------------------|------|

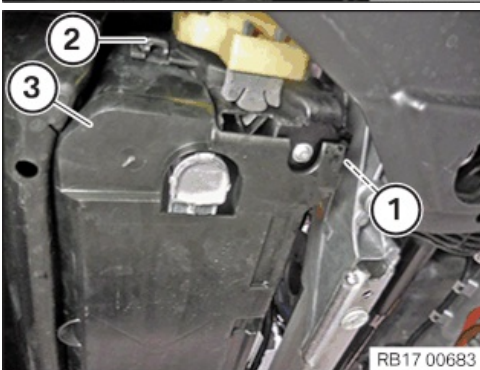

- Insert and install the cover (3) at the bottom left cooling module.
- Ensure that the lock (2) engages audibly.
- Ensure that the lock (1) engages audibly.

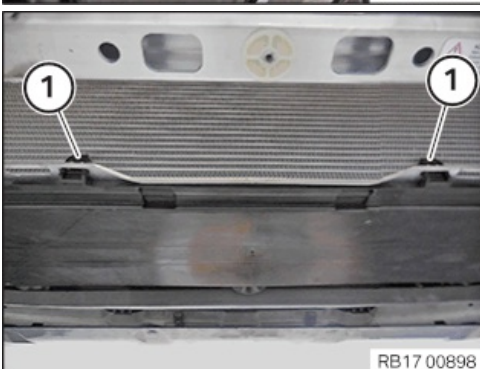

- Ensure that the locks (1) engage audibly.



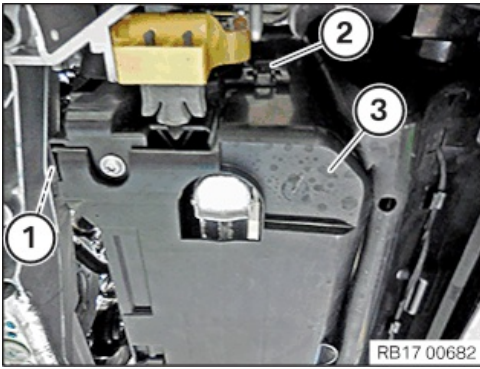

- Feed in and install cover (3) on cooling module, bottom right.
- Ensure that the lock (2) engages audibly.
- Ensure that the lock (1) engages audibly.

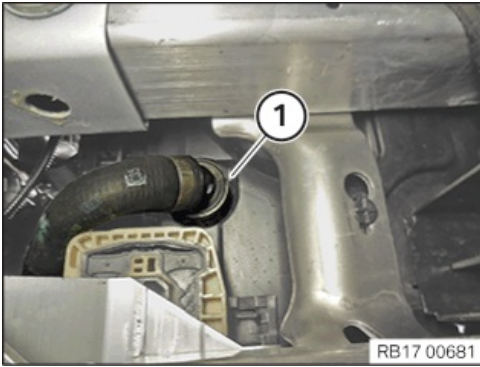

- Connect and lock coolant line (1).
- Make sure that the cooling line (1) engages audibly.

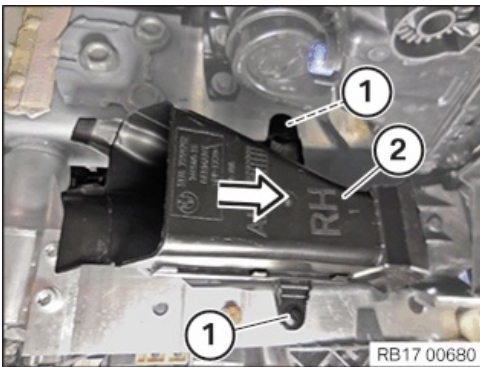

- Feed in air duct (2) in direction of arrow and install.
- Secure clamps (1).

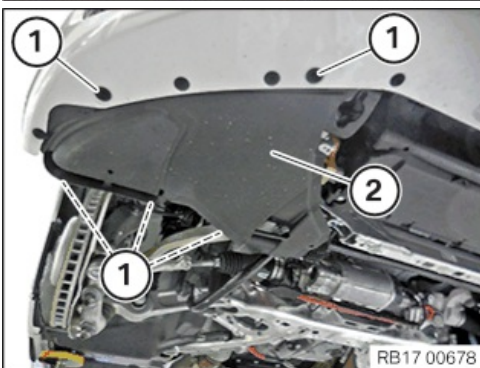

- Guide in and install cover (2), front right.
- Fasten the clamps.
- Tighten the screws (1).

Cover to front bumper

| Screw | Tightening torque |
|-------|-------------------|
| | 3 Nm |

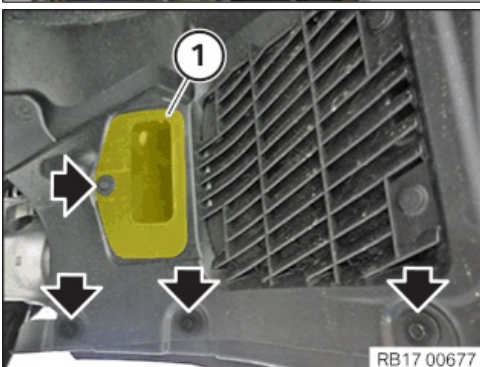

- Thread in air duct (1) and install.
- Tighten screws (arrows).

Cover to front bumper

| Screw | Tightening torque |
|-------|-------------------|
| | 3 Nm |



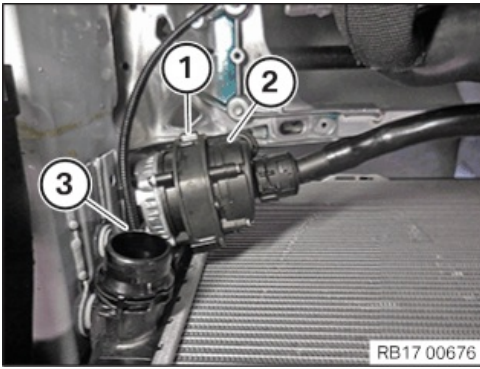

- Feed in and install the electric coolant pump (2).
- Secure the holder (1).
- Secure clamps (3).

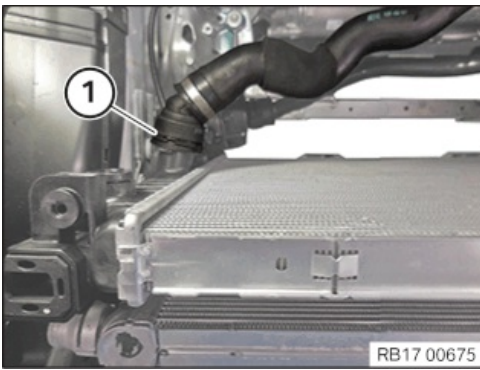

- Connect and lock coolant line (1).
- Make sure that the cooling line (1) engages audibly.

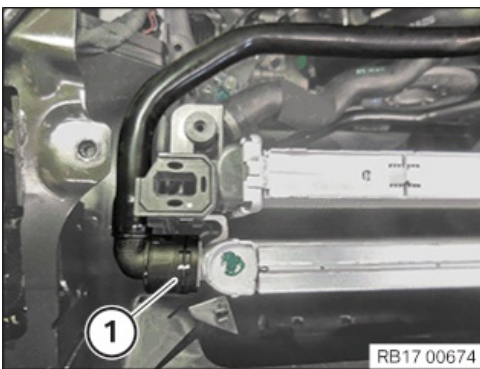

- Connect and lock coolant line (1).
- Make sure that the cooling line (1) engages audibly.

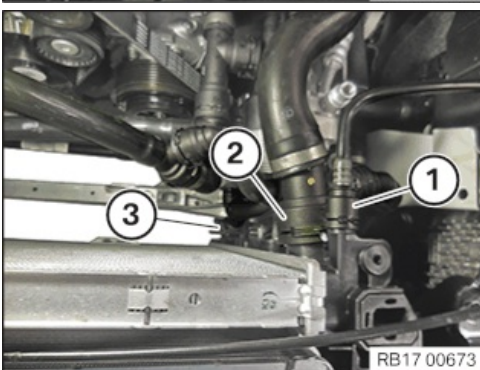

- **If fitted:**
Connect and lock coolant line (3).
- Connect and lock coolant line (2).
- **If fitted:**
Connect and lock coolant line (1).
- Make sure that the coolant lines engage audibly.



- Guide in and install cover (3) on cooling module at the top.
- Ensure that the locks (2) engage audibly.
- Ensure that the locks (1) engage audibly.

POSTPROCESSES

11 – Install fan cowl



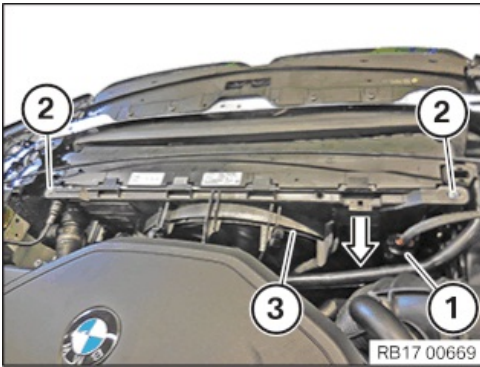

- Feed in and install the fan cowl (3) in the direction of the arrow.
- Tighten the screws (2).

Fan cowl on radiator

| | | | |
|--------|--|--|------|
| TS6x20 | | | 6 Nm |
|--------|--|--|------|

- Connect and lock the connector (1).
The connector (1) must engage audibly.

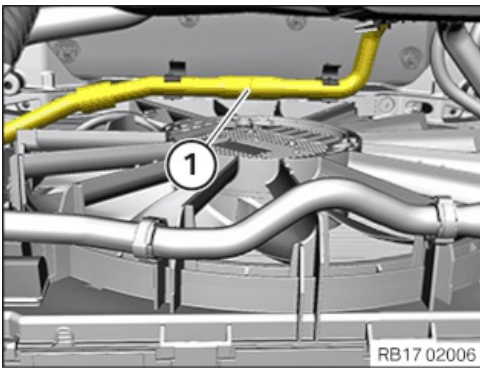

- **If fitted:**
Fasten the coolant line (1) below at the fan cowl with the clamps.

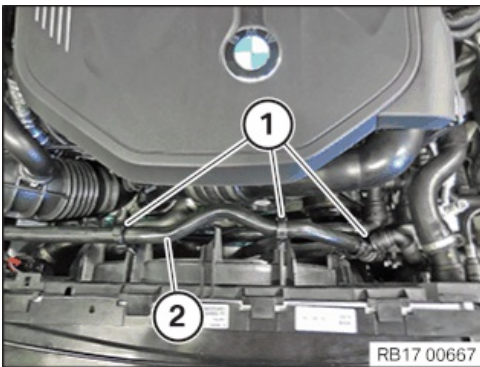

- Feed in and install coolant line (2).
- Lock clamps (1).
The clamps (1) must engage audibly.

12 – Install the rear top cross connection

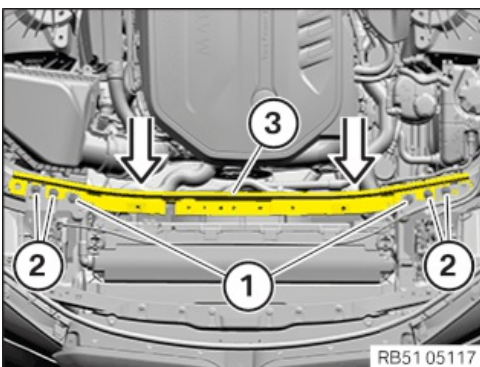

- Guide the cross connection (3) in from the rear in the direction of arrow.
- Tighten down screws (1) and (2).

Top rear cross connection

| | | |
|------------------------|-------------------|-------|
| Torx screw M8x30 | Tightening torque | 19 Nm |
| Hexagon screw M8x20 | Tightening torque | 19 Nm |

13 – Install front cross connection

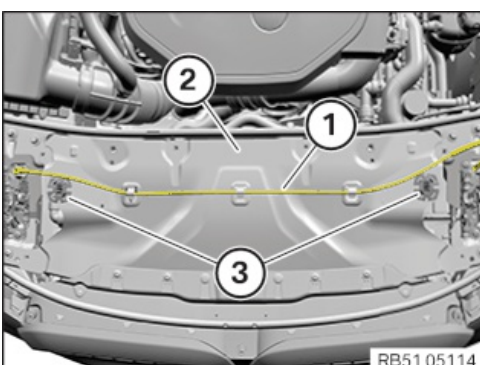

- Feed in cross connection (2) with brackets (3).
- Attach the Bowden cable (1).



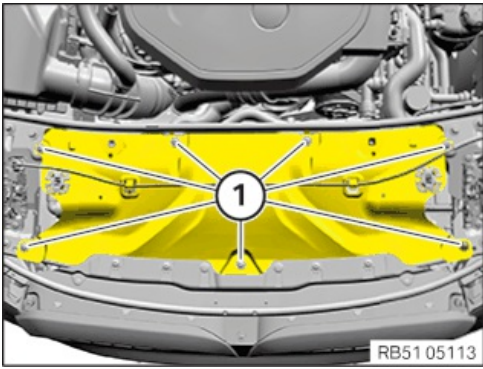

- Tighten the screws (1).

Front cross connection

| | | | |
|-------|--|-------------------|---------|
| Screw | | Tightening torque | 11,8 Nm |
|-------|--|-------------------|---------|

14 – Installing front-end strut on left and right



NOTICE

Description is for left component only. Procedure on the right side is identical.

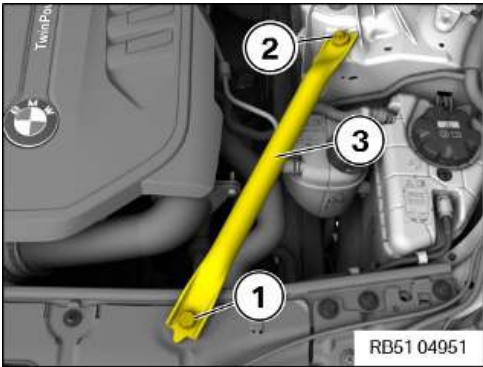

► Installing the front-end strut

- Install the front-end strut (3).



RISK OF DAMAGE

Use of an incorrect tool (impact screwdriver) to release and tighten the screws.

Damaged thread.

- Only use a standard tool (e.g. reversible ratchet) to release/tighten the screw.

- Clean threads on spring strut dome.
- Renew the screw (1).

Parts: Screw

- Tighten down screw (1).

Front-end strut to cross connection

| | | | |
|---------------|--------------|-------------------|-------|
| Hexagon screw | Renew screw. | Jointing torque | 28 Nm |
| | | Angle of rotation | 90 ° |

- Renew the screw (2).

Parts: Screw

- Tighten down screw (2).

Front end strut

| | | | |
|-------|--------------|-------------------|-------|
| Screw | Renew screw. | Jointing torque | 56 Nm |
| | | Angle of rotation | 90 ° |

- Repair damaged threads on the spring strut dome with a Helicoil insert.

Expendable materials

| | | |
|------------------------|-----------|-------------|
| Helicoil thread insert | M10x30 mm | 07129909659 |
|------------------------|-----------|-------------|

15 – Installing the cover on the left and right in the top engine compartment





NOTICE

Description is for left component only. Procedure on the right side is identical.

► Install the cover in the engine compartment on top

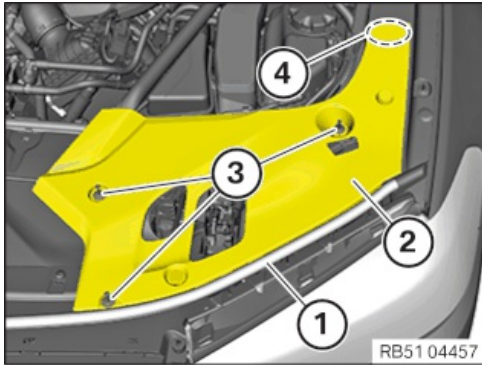

- Insert the cover (2) in the area (4).
- Secure expanding rivet (3).
- Mount seal (1) on cover (2).

16 – Fill the high-temperature cooling system with the vacuum filler device

Vacuum filler device

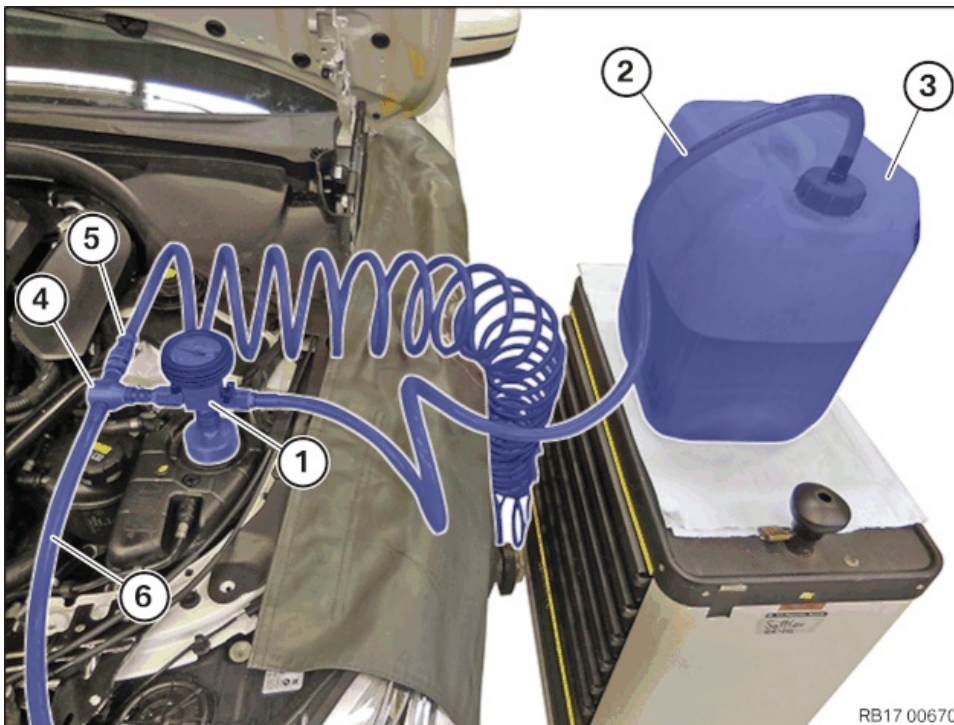

Vacuum filler device - connected to the coolant expansion tank

1 Vacuum filler device with pressure gauge and shutoff valves

2 Filling hose

3 Fluid tank with coolant

4 Venturi nozzle

5 Compressed air connection (maximum 6 bar)

6 Exhaust hose (Routing the exhaust hose to a collecting vessel)

Prerequisite

The coolant expansion tank for the cooling system must be empty. The fluid tank of the vacuum filler device must have a sufficient quantity of premixed coolant, 1 l to 2 l more than the specified capacity for the vehicle. The fluid tank of the vacuum filler device must be positioned at the same height as the coolant expansion tank. The compressed air connection



must have a pressure of 6 bar. Ignition is switched off.



TECHNICAL INFORMATION

Follow notes for repair work on the cooling system.
For additional information see:
Main group 17
17 00 ... Notes for working on the cooling system



TECHNICAL INFORMATION

Life-long fill of coolant!

Do not reuse used coolant.

When replacing and removing components which rely on the corrosion protection effect of the coolant, it is essential to change the coolant. The cooling system must therefore be emptied and refilled.

In the case of other removal work involving the draining of part quantities of coolant, the coolant level must be topped up with new coolant.



TECHNICAL INFORMATION

Mixing different coolants is not permitted.



TECHNICAL INFORMATION

Filling **without** the vacuum filler device (watering can filling) is **not permitted**.

Non-compliance will result in danger of component and/or engine damage.

Filling specification **absolutely must** be adhered to.

Operation of the vehicle is not permitted unless the filling procedure has been completed. Otherwise, functional limitations (degradation) and/or overheating may occur.

A bleeding procedure is required after a part has been exchanged in the cooling system and/or after refilling the cooling system.



TECHNICAL INFORMATION

Make sure that the ignition (terminal 15) is switched off prior to creating the vacuum with the vacuum filler device.

► **Observe the coolant type**



Coolant in the collecting vessel of vacuum filler device

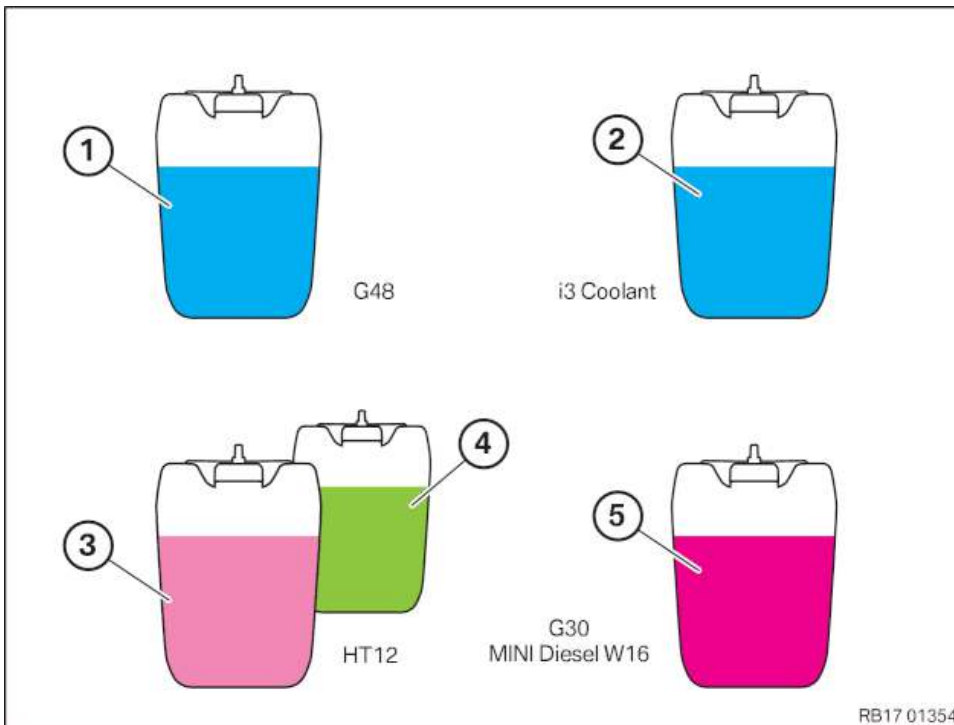

Choose the correct coolant for filling.

In general, a vehicle has to be filled with the coolant with which it is delivered from the factory.

- 1 **G48 (Blue) (BMW LC-87)** Must **not** be mixed with i3 Coolant or G30 MINI Diesel W16.
- 2 **i3 Coolant (Blue) (BMW LC-13)** Is used only for heater circuit i3. i3 Coolant must **not** be added to other coolant circuits or mixed with other coolants.
- 3 **HT12 (Rose) (BMW LC-18)** Must **not** be mixed with i3 Coolant or G30 MINI Diesel W16.
- 4 **HT12 (Green) (BMW LC-18)** Must **not** be mixed with i3 Coolant or G30 MINI Diesel W16.
- 5 **G30 (Rose) (BMW LC-07)** May be W16 used exclusively for the **MINI Diesel**. G30 must **not** be filled in the other coolant circuits or mixed with the other coolants.



RISK OF DAMAGE

Damage to the engine or components in high-voltage vehicles

The use of an incorrect coolant may lead to corrosion or gelling in the coolant circuit.

- Use only approved coolants for the specific vehicle.
- Fill the vehicle only with the coolant with which it was delivered ex works.
- Mix only compatible coolants. The colour does not allow any assessment about the compatibility of coolants.
- Selection of the correct coolant only by means of the part number.



- Select a suitable adapter (Y) from the set of special tools [0 494 417 \(17 0 100\)](#) :

| Type | Engine | Adapter (Y) from 17 0 100 |
|-------------------------------------|---------|---------------------------|
| G11/G12/G14/G15/G16/G30/G31/G32/G38 | B48/B58 | 17 0 103 |

- The fluid tank of the vacuum filler device must be filled with 1 l to 2 l more than the specified capacity of coolant for the vehicle.

Cooling system capacity

| | |
|---|--------|
| B58B30M1 (high-temperature coolant circuit) L802A | 6.06 l |
|---|--------|

Expendable materials: Technically suitable antifreeze and corrosion inhibitor

Cooling system capacity

| | |
|---|-------|
| B58B30M1 High-temperature coolant circuit | 6,9 l |
|---|-------|

| | |
|---|-----|
| B58B30M1 High-temperature coolant circuit (SA823) | 8 l |
|---|-----|

| | |
|--|--------|
| B58B30M1 Low-temperature coolant circuit | 2.95 l |
|--|--------|

Expendable materials: Technically suitable antifreeze and corrosion inhibitor

Cooling system capacity

| | |
|--|--------|
| B58 (high temperature cooling circuit) | 11,3 l |
|--|--------|

| | |
|---------------------------------------|-------|
| B58 (low temperature cooling circuit) | 4,1 l |
|---------------------------------------|-------|

Expendable materials: Technically suitable antifreeze and corrosion inhibitor

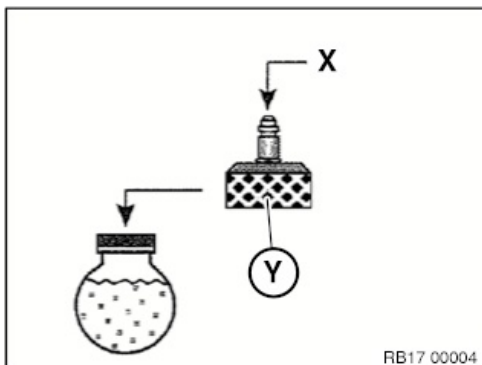

- Connect the selected adapter (Y) to the coolant expansion tank.
- Connect vacuum filler device to connection (X) of the adapter.

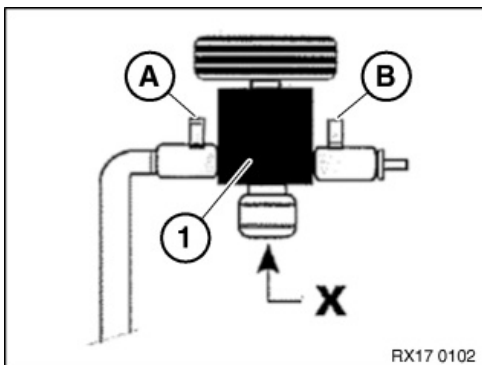

- Check whether shut-off valves (A) and (B) of the vacuum filler device (1) are closed.
- Connect and lock connection (X) to the coolant expansion tank.



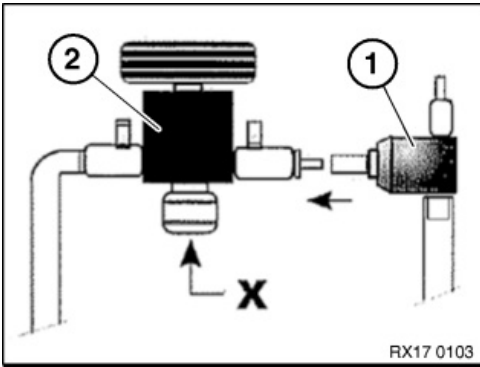

- Connect Venturi nozzle (1) to the vacuum filler device (2).
(X) is the connection on the coolant expansion tank.

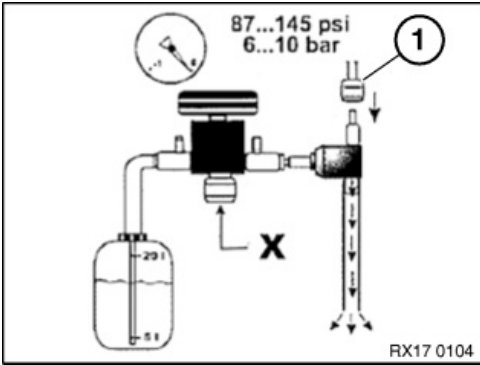

- Connect compressed air (1).
(X) is the connection on the coolant expansion tank.

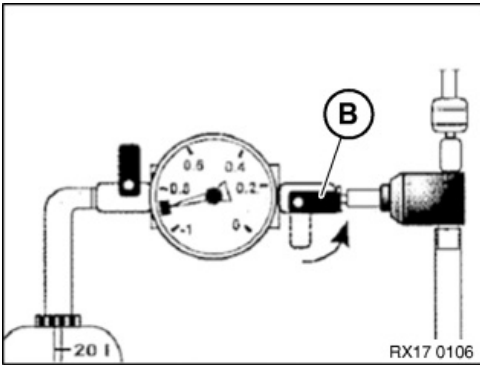

- Open shut-off valve (B).
The Venturi nozzle produces a flow noise.

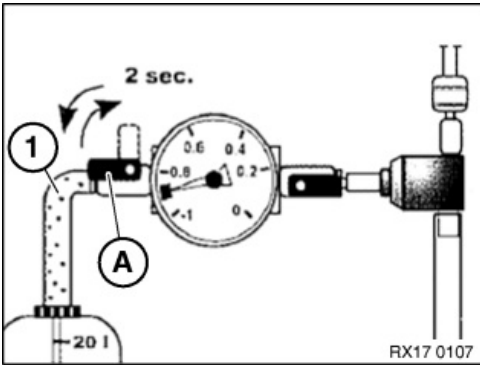

- Open shutoff valve (A) until the fuel filling hose (1) is full without bubbles.
- Close shutoff valve (A) again.
- » The filling hose (1) has now been bled.

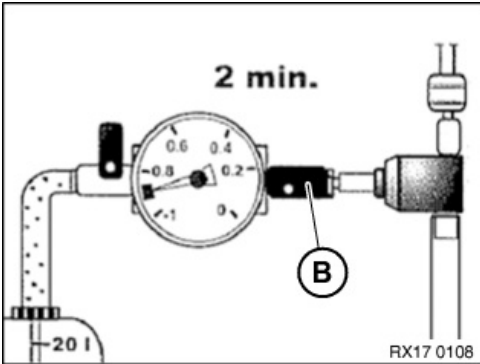

- Check the coolant hoses for porosity and renew porous coolant hoses as required.



TECHNICAL INFORMATION

The coolant hoses contract during vacuum build-up.

- After having established a vacuum in the coolant circuit of between -0.7 to -0.95 bar (duration approximately 2 min), close the shut-off valve (B).



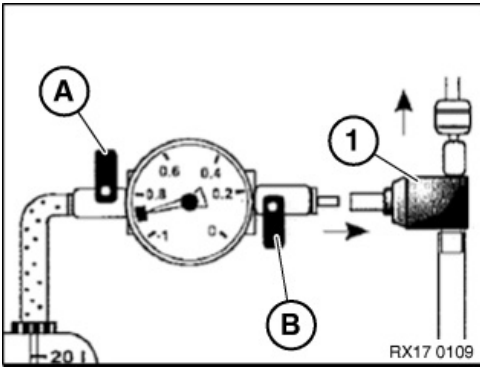

- Check whether the shutoff valves (A) and (B) are closed.
- Disconnect the Venturi nozzle (1).

Check

- Make sure the vacuum in the coolant circuit is maintained for at least 30 seconds.

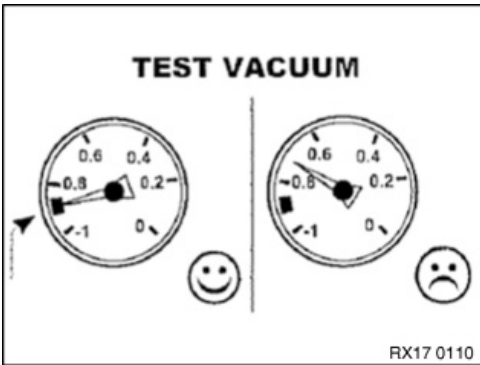

Result

» Vacuum drops.

Measure

- Look for the leak, repair it and start the filling procedure from the beginning.

Check

- Make sure the vacuum in the coolant circuit is maintained for at least 30 seconds.

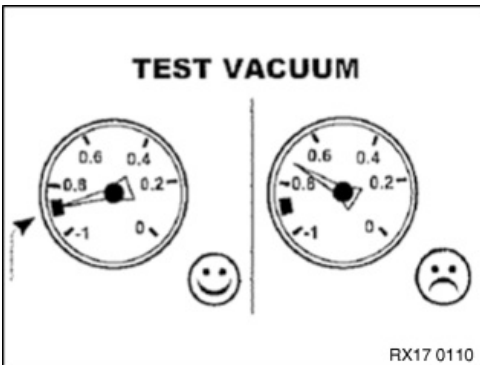

Result

» Vacuum remains constant.

Measure

- Continue with filling.

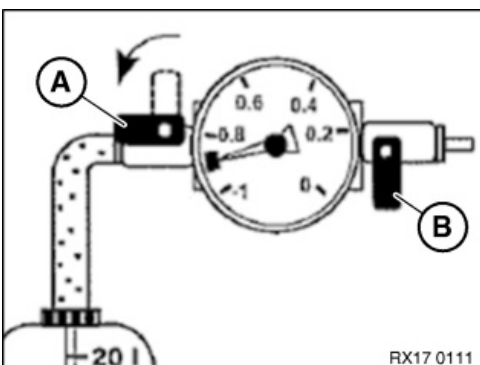

- Keep shutoff valve (B) closed during the filling process.
- To fill the cooling system, open the shutoff valve (A) to the fluid tank of the vacuum filler device.



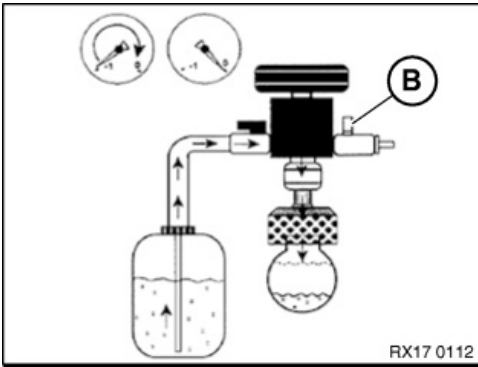

- Stop the filling procedure when the needle in the pressure measuring device is on 0 bar or it no longer drops.
- If necessary, reduce remaining vacuum. In order to do so, open shutoff valve (B).

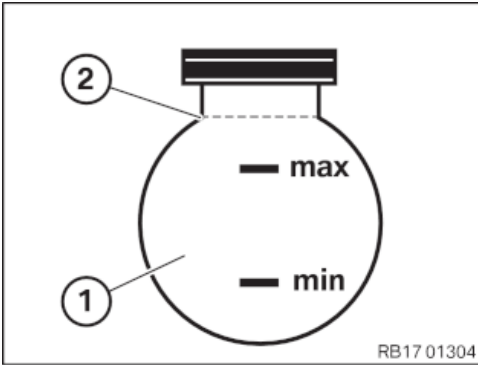

- Remove the vacuum filler device with the adapter from the high temperature coolant expansion tank (1).
- Top up the coolant level in the high temperature coolant expansion tank (1) to the lower edge of the coolant filler neck (2) in the high temperature coolant expansion tank (1).
- After filling the cooling system with the vacuum filler device, **also** run the cooling system bleeding routine.

17 – Filling the low-temperature cooling system with the vacuum filler device

Vacuum filler device

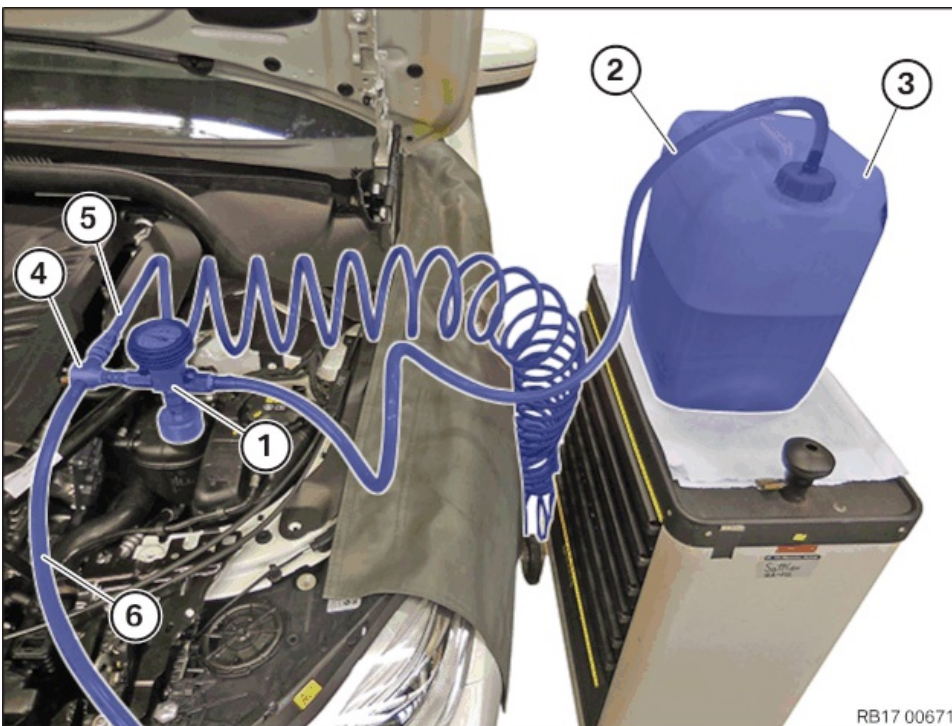

Vacuum filler device - connected to the coolant expansion tank

- 1 Vacuum filler device with pressure gauge and shutoff valves
- 2 Filling hose
- 3 Fluid tank with coolant
- 4 Venturi nozzle
- 5 Compressed air connection (maximum of 6 bar)
- 6 Out-going hose (lead out-going hose into a collecting vessel)

Prerequisite



The coolant expansion tank for the cooling system must be empty. The fluid tank of the vacuum filler device must have a sufficient quantity of premixed coolant, 1 l to 2 l more than the specified capacity for the vehicle. The fluid tank of the vacuum filler device must be positioned at the same height as the coolant expansion tank. The compressed air connection must have a pressure of 6 bar. Ignition is switched off.



TECHNICAL INFORMATION

Follow notes for repair work on the cooling system.

For additional information see:

Main group 17

17 00 ... Notes for working on the cooling system



TECHNICAL INFORMATION

Life-long fill of coolant!

Do not reuse used coolant.

When replacing and removing components which rely on the corrosion protection effect of the coolant, it is essential to change the coolant. The cooling system must therefore be emptied and refilled.

In the case of other removal work involving the draining of part quantities of coolant, the coolant level must be topped up with new coolant.



TECHNICAL INFORMATION

Mixing different coolants is not permitted.



TECHNICAL INFORMATION

Filling **without** the vacuum filler device (watering can filling) is **not permitted**.

Non-compliance will result in danger of component and/or engine damage.

Filling specification **absolutely must** be adhered to.

Operation of the vehicle is not permitted unless the filling procedure has been completed. Otherwise, functional limitations (degradation) and/or overheating may occur.

A bleeding procedure is required after a part has been exchanged in the cooling system and/or after refilling the cooling system.



TECHNICAL INFORMATION

Make sure that the ignition (terminal 15) is switched off prior to creating the vacuum with the vacuum filler device.

► **Observe the coolant type**



Coolant in the collecting vessel of vacuum filler device

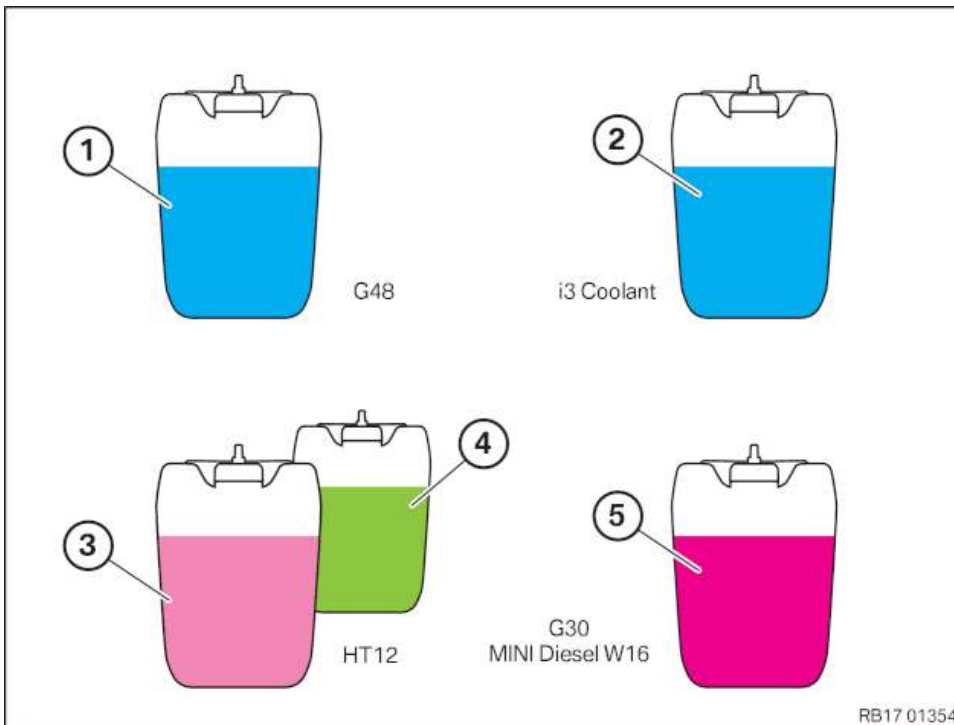

Choose the correct coolant for filling.

In general, a vehicle has to be filled with the coolant with which it is delivered from the factory.

- 1 **G48 (Blue) (BMW LC-87)** Must **not** be mixed with i3 Coolant or G30 MINI Diesel W16.
- 2 **i3 Coolant (Blue) (BMW LC-13)** Is used only for heater circuit i3. i3 Coolant must **not** be added to other coolant circuits or mixed with other coolants.
- 3 **HT12 (Rose) (BMW LC-18)** Must **not** be mixed with i3 Coolant or G30 MINI Diesel W16.
- 4 **HT12 (Green) (BMW LC-18)** Must **not** be mixed with i3 Coolant or G30 MINI Diesel W16.
- 5 **G30 (Rose) (BMW LC-07)** May be W16 used exclusively for the **MINI Diesel**. G30 must **not** be filled in the other coolant circuits or mixed with the other coolants.



RISK OF DAMAGE

Damage to the engine or components in high-voltage vehicles

The use of an incorrect coolant may lead to corrosion or gelling in the coolant circuit.

- Use only approved coolants for the specific vehicle.
- Fill the vehicle only with the coolant with which it was delivered ex works.
- Mix only compatible coolants. The colour does not allow any assessment about the compatibility of coolants.
- Selection of the correct coolant only by means of the part number.



- Select a suitable adapter (Y) from the set of special tools [0 494 417 \(17 0 100\)](#) :

| Type | Engine | Adapter (Y) from 17 0 100 |
|-------------------------------------|---------|---------------------------|
| G11/G12/G14/G15/G16/G30/G31/G32/G38 | B48/B58 | 17 0 109 |

- The fluid tank of the vacuum filler device must be filled with 1 l to 2 l more than the specified capacity of coolant for the vehicle.

Cooling system capacity

| | |
|---|--------|
| B58 (high temperature cooling circuit) | 11,3 l |
| B58 (low temperature cooling circuit) | 4,1 l |
| Expendable materials: Technically suitable antifreeze and corrosion inhibitor | |

Cooling system capacity

| | |
|---|--------|
| B58B30M1 High-temperature coolant circuit | 6,9 l |
| B58B30M1 High-temperature coolant circuit (SA823) | 8 l |
| B58B30M1 Low-temperature coolant circuit | 2,95 l |
| Expendable materials: Technically suitable antifreeze and corrosion inhibitor | |

Expendable materials: Technically suitable antifreeze and corrosion inhibitor

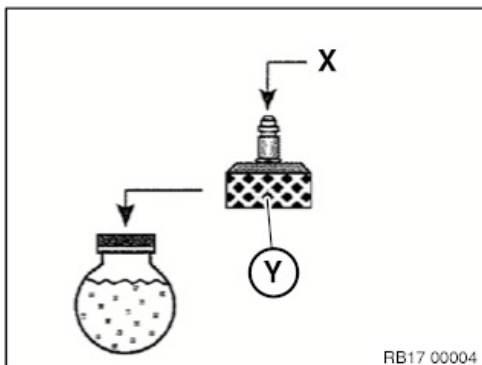

- Connect the selected adapter (Y) to the coolant expansion tank.
- Connect vacuum filler device to connection (X) of the adapter.

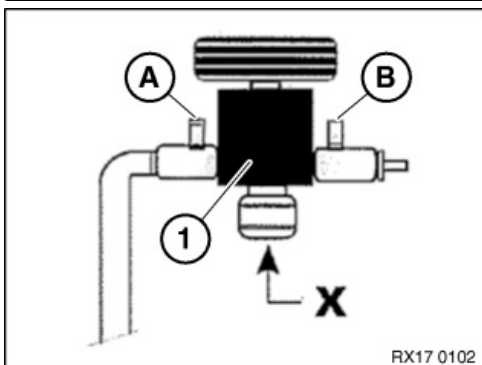

- Check that shutoff valves (A) and (B) of the vacuum filler device (1) are closed.
- Connect and lock connection (X) to the coolant expansion tank.

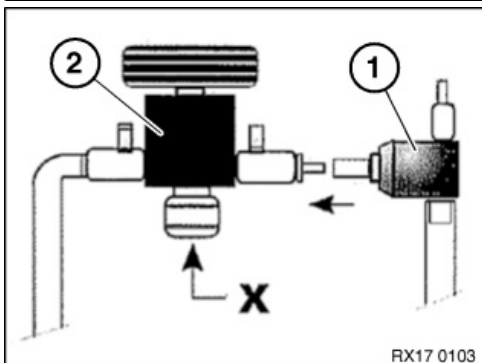

- Connect Venturi nozzle (1) to the vacuum filler device (2). (X) is the connection on the coolant expansion tank.



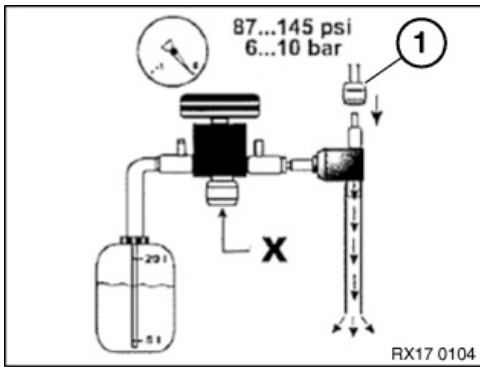

- Connect compressed air (1).
(X) is the connection on the coolant expansion tank.

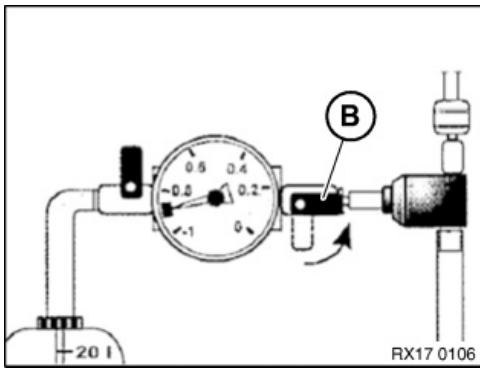

- Open shut-off valve (B).
The Venturi nozzle produces a flow noise.

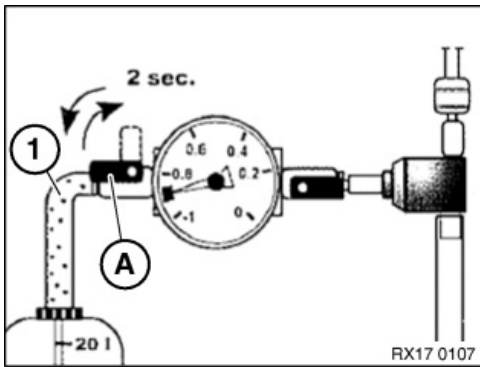

- Open shutoff valve (A) until the fuel filling hose (1) is full without bubbles.
- Close shutoff valve (A) again.
- » The filling hose (1) has now been bled.

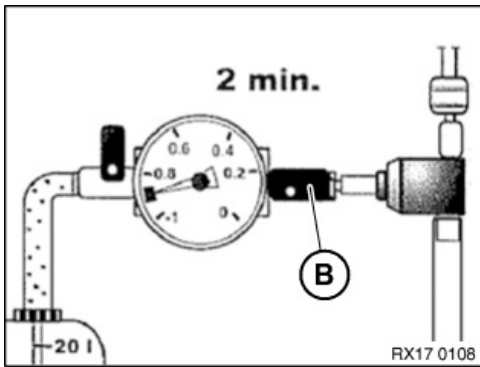

- Check the coolant hoses for porosity and renew porous coolant hoses as required.



TECHNICAL INFORMATION

The coolant hoses contract during vacuum build-up.

- After a vacuum of -0.7 to -0.95 bar has been created in the coolant circuit (duration approx. 2 min), shut the shutoff valve (B).

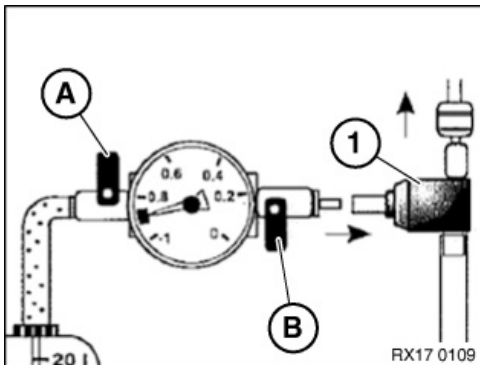

- Check whether the shutoff valves (A) and (B) are closed.
- Disconnect the Venturi nozzle (1).

Check



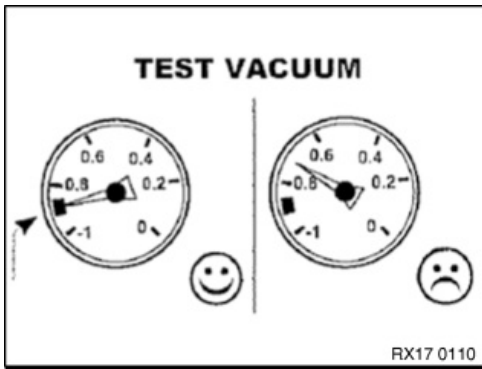

- The vacuum in the coolant circuit must be maintained for at least 30 seconds.

Result

- » Vacuum drops.

Measure

- Look for the leak, repair it and start the filling procedure from the beginning.

Check

- The vacuum in the coolant circuit must be maintained for at least 30 seconds.

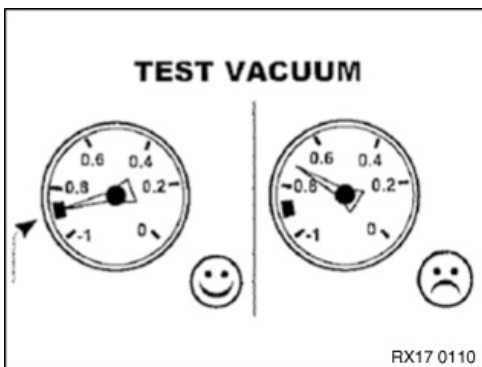

Result

- » Vacuum remains constant.

Measure

- Continue with filling.

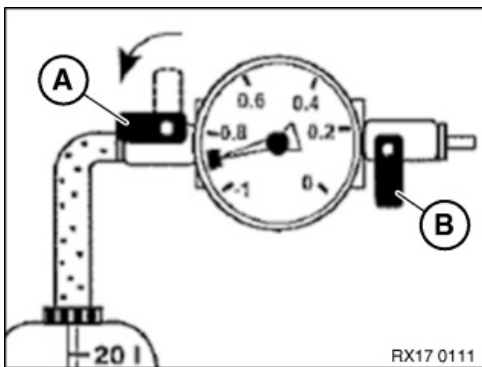

- Keep shutoff valve (B) closed during the filling process.
- To fill the cooling system, open the shutoff valve (A) to the fluid tank of the vacuum filler device.

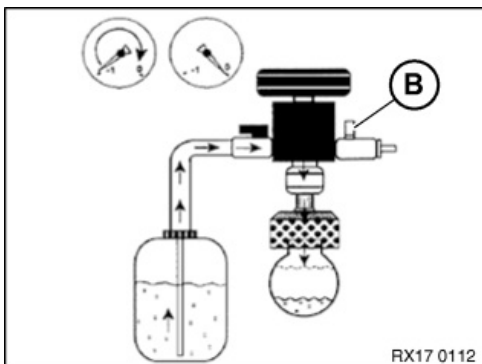

- Stop the filling procedure when the needle in the pressure measuring device is on 0 bar or it no longer drops.
- If necessary, reduce remaining vacuum. In order to do so, open shutoff valve (B).



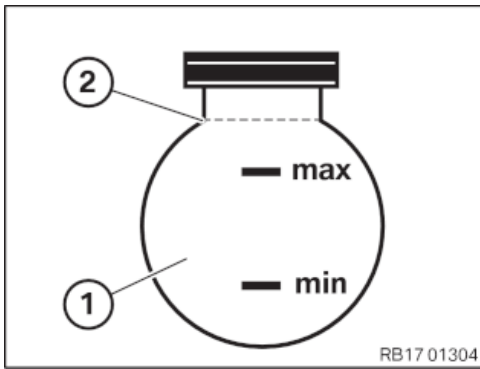

- Remove the vacuum filler device with the adapter from the low-temperature coolant expansion tank (1).
- Adjust the coolant level in the low-temperature coolant expansion tank (1) up to the lower edge of the coolant filler neck (2) of the low-temperature coolant expansion tank (1).
- After filling the cooling system with the vacuum filler device, **also** run the cooling system bleeding routine.

18 – Bleed the high-temperature coolant circuit

Bleed the high-temperature coolant system

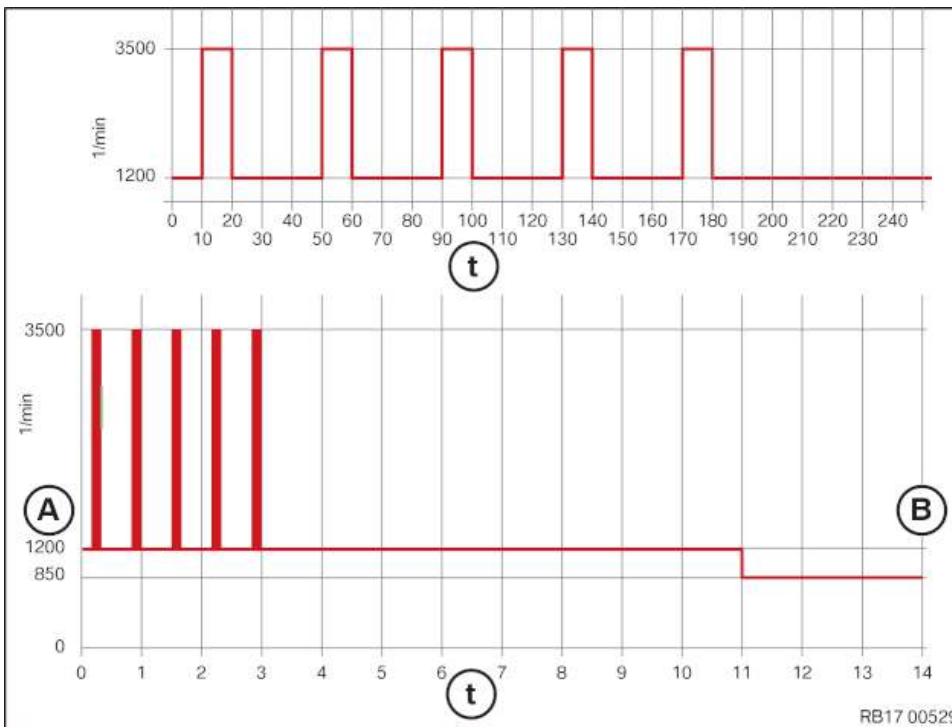

A = increased idle speed

B = Cooling system bleeding routine finished

t = Time



TECHNICAL INFORMATION

Filling **without** the vacuum filler device (watering can filling) is **not permitted**.

Non-compliance will result in danger of component and/or engine damage.

Filling specification **absolutely must** be adhered to.

Operation of the vehicle is not permitted unless the filling procedure has been completed. Otherwise, functional limitations (degradation) and/or overheating may occur.

A bleeding procedure is required after a part has been exchanged in the cooling system and/or after refilling the cooling system.





TECHNICAL INFORMATION

Before starting the automatic cooling system bleeding routine, make sure that **both coolant circuits** are **filled**. The cooling system bleeding routine is automatically started simultaneously for both coolant circuits. If the cooling system bleeding routine is started while one of the coolant circuits is empty, there is a risk of damage to the electric coolant pump when running it dry.

Make sure that terminal 15 is not disconnected for the bleeding procedure. Switch on low-beam headlights and hazard warning lights. If the low-beam headlights and hazard warning lights are not switched on, the ignition (terminal 15) will switch off automatically after a certain period of time and interrupt the bleeding procedure.



TECHNICAL INFORMATION

Life-long fill of coolant!

Do not reuse used coolant.

When replacing and removing components which rely on the corrosion protection effect of the coolant, it is essential to change the coolant. The cooling system must therefore be emptied and refilled.

In the case of other removal work involving the draining of part quantities of coolant, the coolant level must be topped up with new coolant.



TECHNICAL INFORMATION

During the cooling system bleeding routine, the electric fan may be activated sporadically.



- Remove the vacuum filler device from the coolant expansion tank of the high-temperature coolant system.
- Open the bleeder screw on the coolant expansion tank for the high-temperature coolant circuit and close it again after approx. **10 s**.

You can close the bleeder screw prior to expiry of the 10 s once coolant escapes.

- Adjust the filling level in the coolant expansion tank of the high-temperature cooling system to the maximum mark.
- Close the sealing cap on the coolant expansion tank of the high-temperature cooling circuit.
- Connect battery charger.
- Close driver's seat belt.
- **Activate** the testing-analysis-diagnosis (PAD) by quickly pressing the START-STOP button 3 times.
- Adjust the heating to **maximum** temperature and adjust the blower to the **lowest** stage.
- Floor the accelerator pedal and hold for **15 s**.

The automatic cooling system bleeding routine will be initiated.

- Start engine.

The Idle speed is automatically increased to **1200 rpm**.

- **Press accelerator pedal until engine speed reaches approx. 3500 rpm, maintain this engine speed for 10 s .**
- Hold idle speed for **30 s**.
- **Press accelerator pedal until engine speed reaches approx. 3500 rpm, maintain this engine speed for 10 s .**
- Hold idle speed for **30 s**.
- **Press accelerator pedal until engine speed reaches approx. 3500 rpm, maintain this engine speed for 10 s .**
- Hold idle speed for **30 s**.
- **Press accelerator pedal until engine speed reaches approx. 3500 rpm, maintain this engine speed for 10 s .**
- Hold idle speed for **30 s**.
- **Press accelerator pedal until engine speed reaches approx. 3500 rpm, maintain this engine speed for 10 s .**
- Hold idle speed for **30 s**.

The cooling system bleeding routine has finished approximately **11 min** after the engine starts.

The engine speed drops to the **idle speed** again.

- Switch off engine.
- Allow the engine to cool down.
- Adjust the filling level in the coolant expansion tank of the high-temperature coolant circuit to 200 ml above the maximum mark.



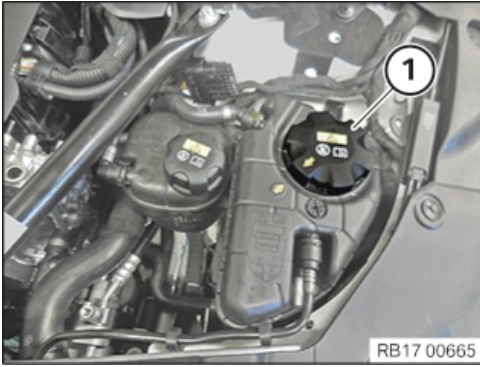

- Close the sealing cap (1) until the **arrows** are flush.

19 – Bleeding the low-temperature cooling system



TECHNICAL INFORMATION

Life-long fill of coolant!

Do not reuse used coolant.

When replacing and removing components which rely on the corrosion protection effect of the coolant, it is essential to change the coolant. The cooling system must therefore be emptied and refilled.

In the case of other removal work involving the draining of part quantities of coolant, the coolant level must be topped up with new coolant.



TECHNICAL INFORMATION

Before starting the automatic cooling system bleeding routine, make sure that **both coolant circuits** are **filled**. The cooling system bleeding routine is automatically started simultaneously for both coolant circuits. If the cooling system bleeding routine is started while one of the coolant circuits is empty, there is a risk of damage to the electric coolant pump when running it dry.

Make sure that terminal 15 is not disconnected for the bleeding procedure. Switch on low-beam headlights and hazard warning lights. If the low-beam headlights and hazard warning lights are not switched on, the ignition (terminal 15) will switch off automatically after a certain period of time and interrupt the bleeding procedure.



TECHNICAL INFORMATION

Filling **without** the vacuum filler device (watering can filling) is **not permitted**.

Non-compliance will result in danger of component and/or engine damage.

Filling specification **absolutely must** be adhered to.

Operation of the vehicle is not permitted unless the filling procedure has been completed. Otherwise, functional limitations (degradation) and/or overheating may occur.

A bleeding procedure is required after a part has been exchanged in the cooling system and/or after refilling the cooling system.



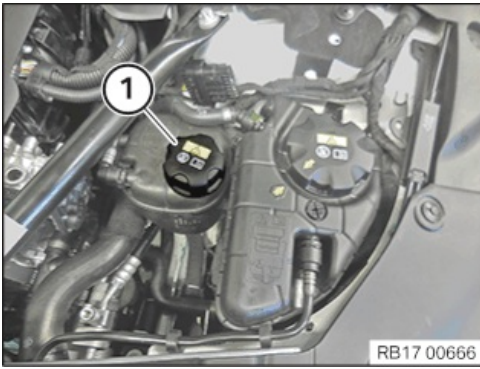

- Remove the vacuum filler device from the coolant expansion tank of the low-temperature coolant circuit.
- Adjust the coolant level in the coolant expansion tank of the low-temperature coolant circuit to the maximum mark.
- Close the sealing cap (1) on the coolant expansion tank of the low-temperature coolant circuit.
- Connect battery charger.
- **Activate** the testing-analysis-diagnosis (PAD) by quickly actuating the START-STOP button three times.
- Activate the low-beam headlight and the hazard warning lights **at the same time**.

If the low-beam headlight and the hazard-warning lights are **not** switched on, then the ignition (**terminal 15**) will automatically switch off after some time and interrupt the bleeding procedure.

- Close driver's door.
- Adjust the heating to **maximum** temperature and adjust the blower to the **lowest** stage.
- Floor the accelerator pedal and hold for 15 s.

The automatic cooling system bleeding routine will be initiated.

The cooling system bleeding routine ends automatically after approximately 11 minutes.

- Adjust the filling level in the coolant expansion tank of the low-temperature coolant circuit to **100 ml** above the **maximum mark** (1).

20 – Installing the underbody protection of the steering gear or the front stiffening plate



TECHNICAL INFORMATION

Different variants may be installed depending on the vehicle equipment.

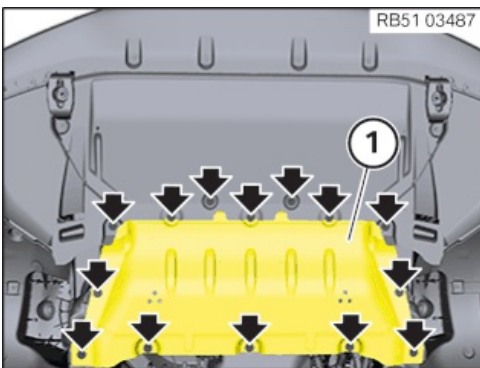

- **Version A:**
Insert steering gear aggregate protective plate (1).
Tighten screws (arrows).

Underbody protection

| Screw | Tightening torque | 3 Nm |
|-------|-------------------|------|
| | | |



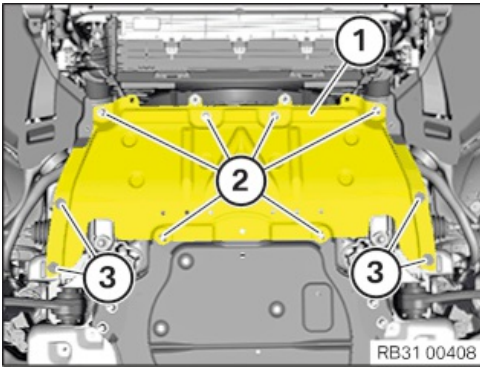

• **Version B:**

Renew screws (2).

Parts: Screws

Position the front stiffening plate (1).

Tighten the screws (2).

Stiffening plate to front axle support

| | | | |
|----|---------------|-------------------|-------|
| M8 | Renew screws. | Jointing torque | 25 Nm |
| | | Angle of rotation | 70 ° |

- Tighten the screws (3).

Cover, steering unit

| | | | |
|-------|--|-------------------|------|
| Screw | | Tightening torque | 3 Nm |
|-------|--|-------------------|------|

21 – Install front underbody protection and/or front stiffening plate



TECHNICAL INFORMATION

Different variants may be installed depending on the vehicle equipment.

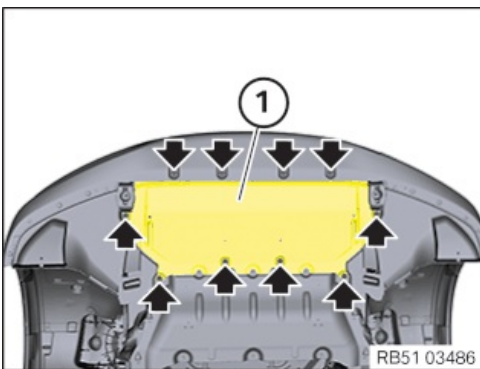

• **Version A:**

Insert the front underbody protection (1).

Tighten screws (arrows).

Underbody protection

| | | | |
|-------|--|-------------------|------|
| Screw | | Tightening torque | 3 Nm |
|-------|--|-------------------|------|

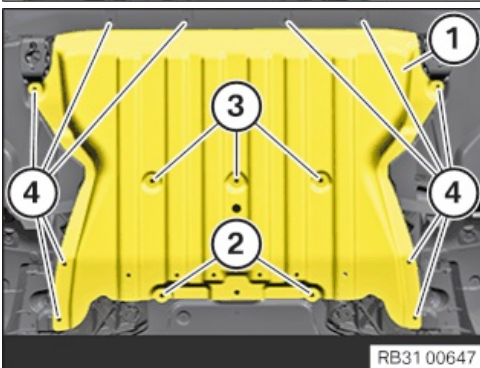

• **Version B:**

Position the front stiffening plate (1).

Renew screws (2).

Parts: Screws

Tighten the screws (2).

Stiffening plate to front axle support

| | | | |
|----|---------------|-------------------|-------|
| M8 | Renew screws. | Jointing torque | 25 Nm |
| | | Angle of rotation | 70 ° |

- Tighten the screws (3).

- Tighten the screws (4).

Underbody protection

| | | | |
|-------|--|-------------------|------|
| Screw | | Tightening torque | 3 Nm |
|-------|--|-------------------|------|

Additional Information

Overview of Tightening Torques



| | | | |
|---|---------------|-------------------|-------------------|
| Radiator to cooling module, bottom | | | Used in step 10 |
| TS6x20 | | Tightening torque | 6 Nm |
| Cover to front bumper | | | Used in step 10 |
| Screw | | Tightening torque | 3 Nm |
| Fan cowl on radiator | | | Used in step 11 |
| TS6x20 | | | 6 Nm |
| Top rear cross connection | | | Used in step 12 |
| Torx screw M8x30 | | Tightening torque | 19 Nm |
| Hexagon screw M8x20 | | Tightening torque | 19 Nm |
| Front cross connection | | | Used in step 13 |
| Screw | | Tightening torque | 11,8 Nm |
| Front-end strut to cross connection | | | Used in step 14 |
| Hexagon screw | Renew screw. | Jointing torque | 28 Nm |
| | | Angle of rotation | 90 ° |
| Front end strut | | | Used in step 14 |
| Screw | Renew screw. | Jointing torque | 56 Nm |
| | | Angle of rotation | 90 ° |
| Underbody protection | | | Used in step 2021 |
| Screw | | Tightening torque | 3 Nm |
| Stiffening plate to front axle support | | | Used in step 2021 |
| M8 | Renew screws. | Jointing torque | 25 Nm |
| | | Angle of rotation | 70 ° |
| Cover, steering unit | | | Used in step 20 |
| Screw | | Tightening torque | 3 Nm |

Overview of Special Tools

0 494 417 (17 0 100) Tester

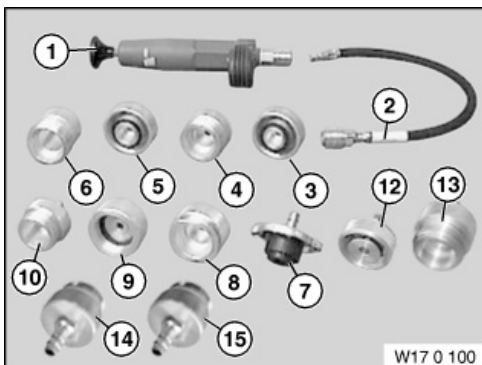

Common Used in step 1617

| | |
|------------------------------|---|
| Usage | For checking engine cooling system on watertightness. For checking radiator cap. |
| Included in the tool or work | |
| Storage location | Individual |
| Replaced by | |
| In connection with | |
| SI-Number | 01 07 02 (884) |

Consisting of

| Pos | BMW Order number | Replaced by | Designation | In Connection with |
|-----|------------------|-------------|-------------|--------------------|
|-----|------------------|-------------|-------------|--------------------|



| | | |
|----|----------------------|--|
| 5 | 0 494 422 (17 0 105) | Adapter For radiator cap (sawtooth thread) |
| 10 | 0 494 427 (17 0 111) | Adapter For radiator cap R53/W11, R50/W17 adapter replaced 17 0 052. |
| 1 | 0 494 418 (17 0 101) | Pump Replacement part for set 8330 0494417 (170100) |
| 2 | 0 494 419 (17 0 102) | Hose (hose with quick-release coupling) |
| 3 | 0 494 420 (17 0 103) | Adapter For radiator cap (normal thread) |
| 4 | 0 494 421 (17 0 104) | Adapter For radiator cap (normal thread) |
| 6 | 0 494 423 (17 0 106) | Adapter For radiator cap (sawtooth thread) |
| 7 | 0 494 424 (17 0 107) | Adapter For radiator cap R50 / W10 |
| 8 | 0 494 425 (17 0 108) | Adapter For radiator cap R50 / W10 |
| 9 | 0 494 426 (17 0 109) | Adapter For radiator connection R53/W11, R50/W17 adapter corresponds to 17 0 051 |
| 11 | 0 494 428 (17 0 112) | Case |
| 12 | 0 494 642 (17 0 113) | Adapter For radiator cap Model series: E60, E61, E63, E64 SI no.: 1 08 03 (988) |
| 13 | 0 494 643 (17 0 114) | Adapter For radiator cap Model series: E60, E61, E63, E64 SI no.: 1 08 03 (988) |
| 14 | 0 495 889 (17 0 115) | Adapter For radiator cap Model series: N12, N14 |

Overview Technical Data

Cooling system capacity

Used in step 16

B58B30M1 (high-temperature coolant circuit) L802A

6.06 I

Expendable materials: Technically suitable antifreeze and corrosion inhibitor

Cooling system capacity

Used in step 1617



| | |
|---|--------|
| B58B30M1 High-temperature coolant circuit | 6,9 l |
| B58B30M1 High-temperature coolant circuit (SA823) | 8 l |
| B58B30M1 Low-temperature coolant circuit | 2.95 l |

Expendable materials: Technically suitable antifreeze and corrosion inhibitor

| | | |
|--------------------------------|--------------|------|
| Cooling system capacity | Used in step | 1617 |
|--------------------------------|--------------|------|

| | |
|--|--------|
| B58 (high temperature cooling circuit) | 11,3 l |
| B58 (low temperature cooling circuit) | 4,1 l |

Expendable materials: Technically suitable antifreeze and corrosion inhibitor

Links

| Repair instructions | Used in step |
|--|---------------------|
| 17 00 ... Instructions for repair work on cooling system | 8101617 |

| Operating materials | Used in step |
|----------------------------|---------------------|
| Main group 17 | 81617 |



17 11 000 Removing and installing coolant radiator

Prerequisite

- Switch off ignition.



WARNING

Hot surfaces.

Risk of burning!

- Perform all work only on components that have cooled down.

PRELIMINARY WORK

1 – Removing the cover on the left and right in the top engine compartment



NOTICE

Description is for left component only. Procedure on the right side is identical.

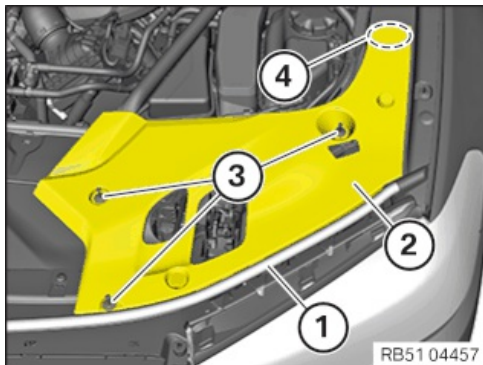

► Remove the cover in the engine compartment on top

- Detach the gasket (1) in the area of the cover (2).
- Loosen the expanding rivet (3).
- Guide out and remove the cover (2) in the area (4).

2 – Remove both front-end struts



NOTICE

Description is for left component only. Procedure on the right side is identical.

► Removing the front-end strut



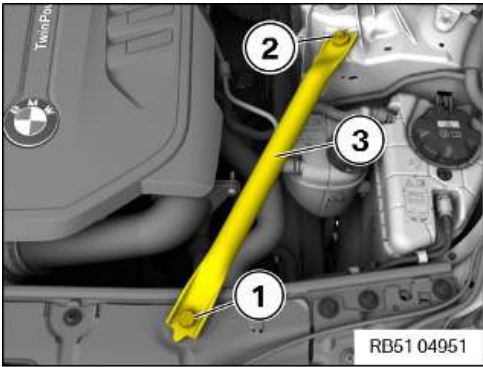

RISK OF DAMAGE

Use of an incorrect tool (impact screwdriver) to release and tighten the screws.

Damaged thread.

- Only use a standard tool (e.g. reversible ratchet) to release/tighten the screw.

- Loosen screws (1) and (2).
- Remove the front-end strut (3).

3 – Remove front cross connection

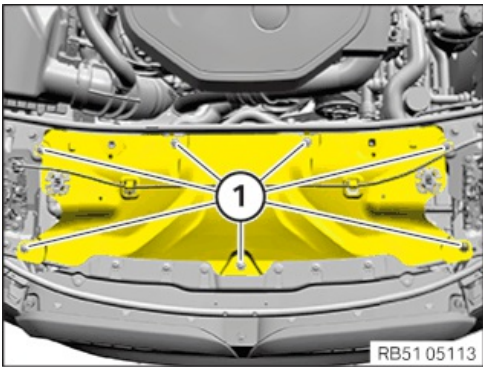

- Loosen screws (1).

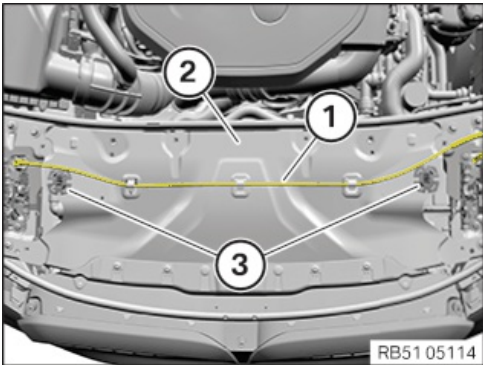

- Detach the Bowden cable (1).
- Feed out cross connection (2) with brackets (3) and remove.

4 – Remove the rear top cross connection

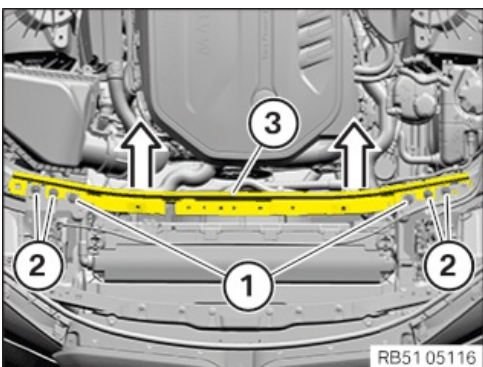

- Loosen screws (1) and (2).
- Guide the cross connection (3) out in the direction of the arrow.

5 – Removing the fan cowl





WARNING

Hot surfaces.

Risk of burning!

- Perform all work only on components that have cooled down.

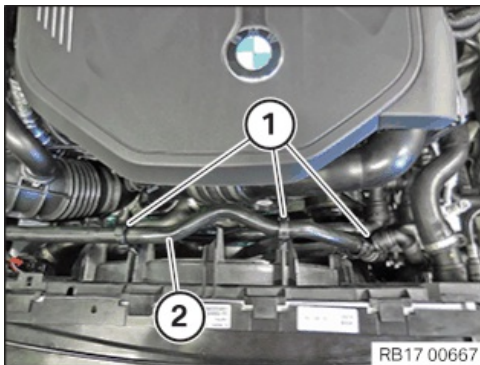

- Unlock and loosen the clamps (1).
- Feed out coolant line (2) and place to one side.

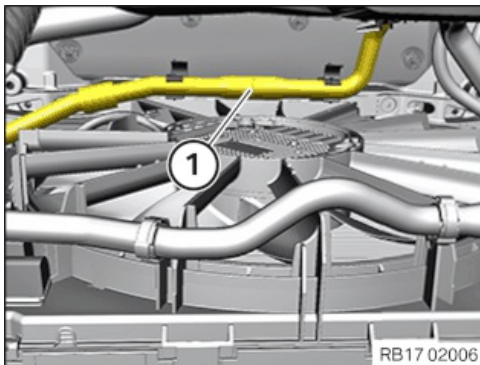

- **If fitted:**

Release the coolant line (1) below at the fan cowl from the clamps and place it to the side.

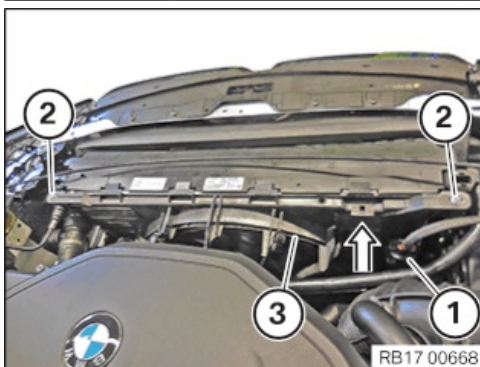

- Unlock and loosen connector (1).
- Loosen screws (2).
- Guide out fan cowl (3) in direction of arrow and remove.

6 – Remove rear underbody protection



NOTICE

To provide a better overview: Schematic diagram with partially hidden components.



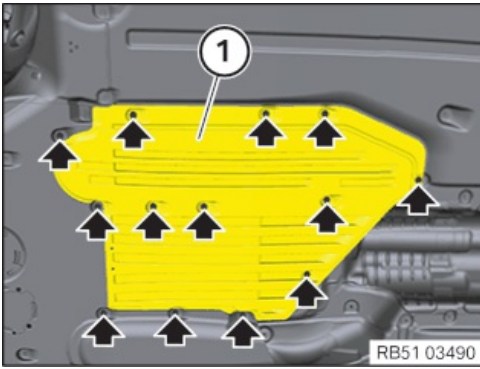

- **Version A:**
Remove screws (arrows).
Feed out the rear underbody protection (1).

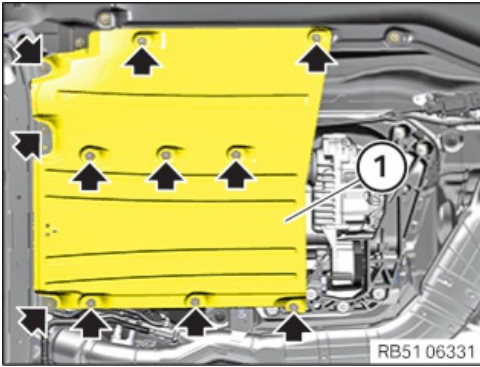

- **Version B:**
Remove screws (arrows).
Guide out rear underbody protection (1) and remove it.

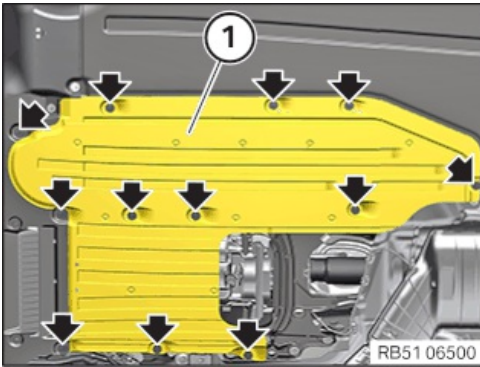

- **Version C:**
Remove screws (arrows).
Guide out rear underbody protection (1) and remove it.

7 – Remove front underbody protection and/or front stiffening plate



TECHNICAL INFORMATION

Different variants may be installed depending on the vehicle equipment.

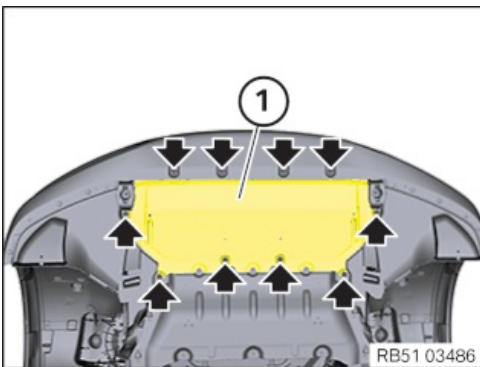

- **Version A:**
Remove screws (arrows).
Feed out the front underbody protection (1).



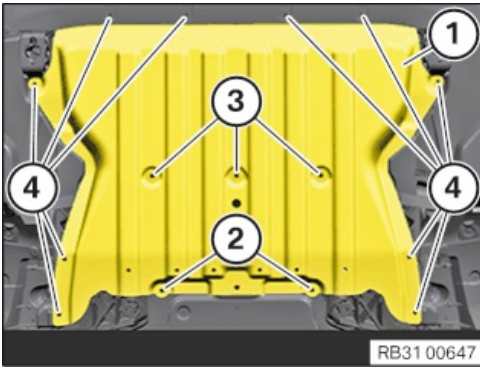

TECHNICAL INFORMATION

Driving without stiffening plate is not permissible.

- **Version B:**
Loosen screws (2) to (4).
Remove the front stiffening plate (1).

8 – Removing the underbody protection of the steering gear and front stiffening plate respectively



TECHNICAL INFORMATION

Different variants may be installed depending on the vehicle equipment.

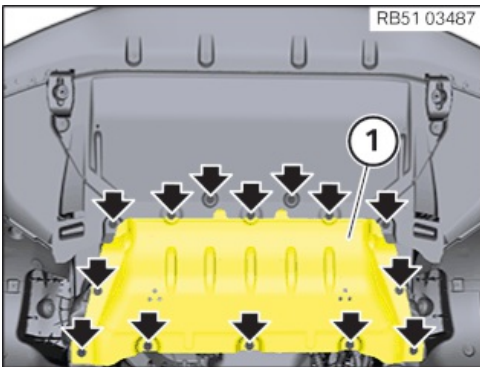

- **Version A:**
Release all bolts (arrows).
Guide out underbody protection (1) of the steering gear.

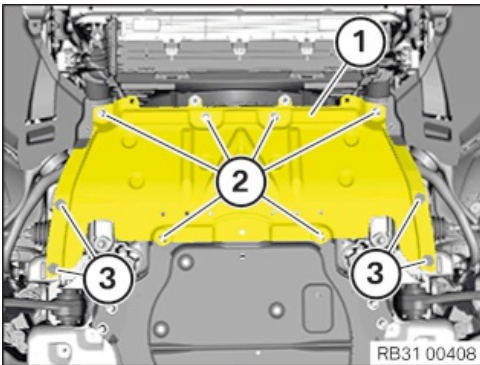

TECHNICAL INFORMATION

Driving without stiffening plate is not permissible.

- **Version B:**
Loosen screws (3).
Loosen screws (2).
Remove front stiffening plate (1).

MAIN WORK

9 – Remove the radiator of the high-temperature coolant circuit



WARNING

Hot surfaces.

Risk of burning!

- Perform all work only on components that have cooled down.





CAUTION

Materials harmful to health.

Contact with fluids harmful to health!

- Note and follow safety information on containers.
- Conduct all work in appropriate personal protective equipment only.



TECHNICAL INFORMATION

Life-long fill of coolant!

Do not reuse used coolant.

When replacing and removing components which rely on the corrosion protection effect of the coolant, it is essential to change the coolant. The cooling system must therefore be emptied and refilled.

In the case of other removal work involving the draining of part quantities of coolant, the coolant level must be topped up with new coolant.



TECHNICAL INFORMATION

Follow notes for repair work on the cooling system.

For additional information see:

Main group 17

17 00 ... Notes for working on the cooling system



TECHNICAL INFORMATION

Collect and dispose of emerging fluids. Observe country-specific waste disposal regulations.

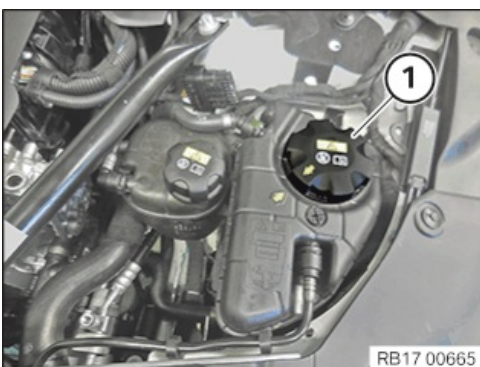

- Loosen sealing cap (1).

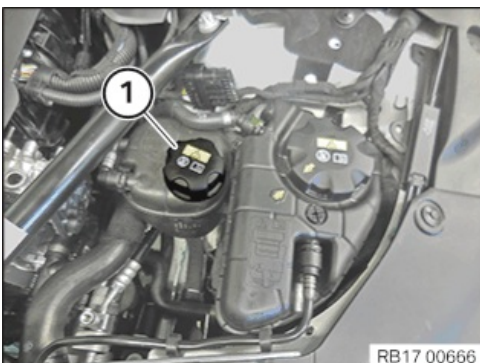

- Loosen sealing cap (1).





RB17 00672

- Unlock the locks (1).
- Unlock the locks (2).
- Remove the cover (3) of the top cooling module.

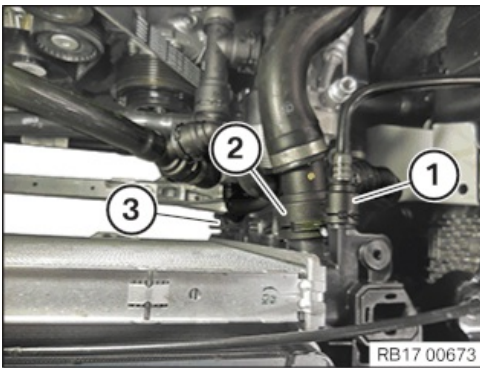

RB17 00673



NOTICE

The following work step(s) is / are to be carried out if the specified component(s) is/are fitted.

- Unlock and loosen coolant line (1).
- Unlock and loosen coolant line (2).
- Unlock and loosen coolant line (3).
- Catch and dispose of escaping coolant.

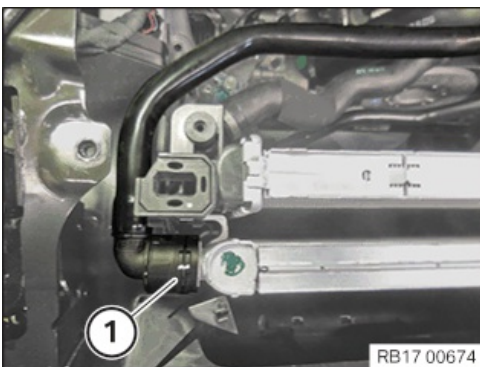

RB17 00674

- Unlock and loosen coolant line (1).
- Catch and dispose of escaping coolant.

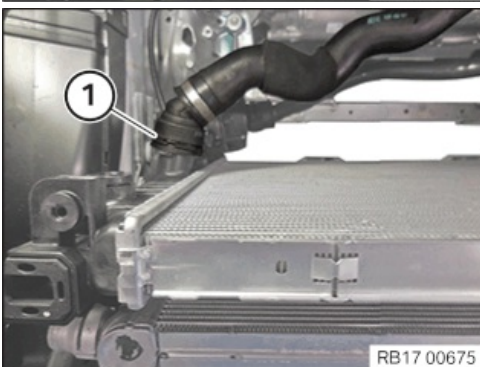

RB17 00675

- Unlock and loosen coolant line (1).
- Catch and dispose of escaping coolant.

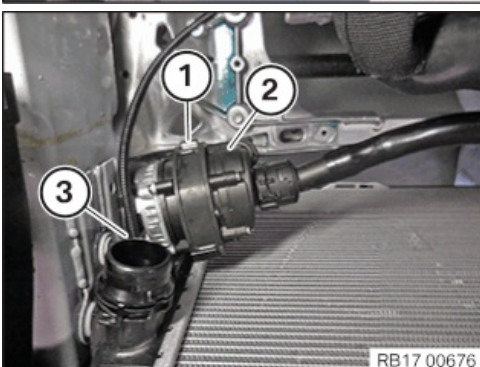

RB17 00676

- Loosen the holder (1).
- Remove the electric coolant pump (2) and put to one side.
- Loosen clamp (3).



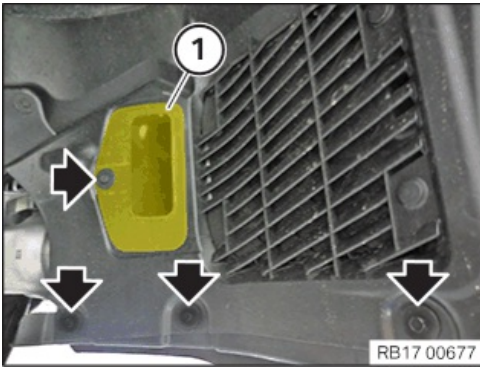

- Remove screws (arrows).
- Thread out air duct (1) and remove.

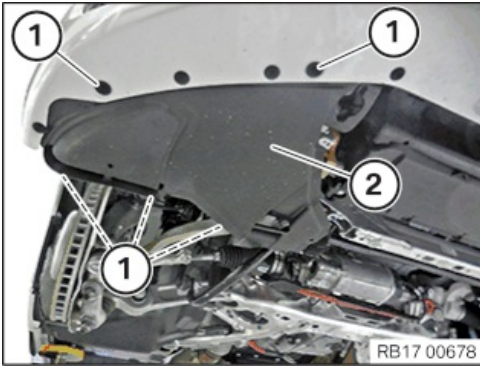

- Loosen clamps .
- Loosen screws (1).
- Guide out and remove the cover (2).

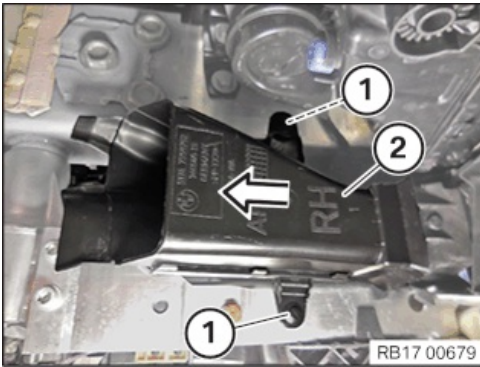

- Loosen clamps (1).
- Guide out air duct (2) in direction of arrow and remove.



- Unlock and loosen coolant line (1).
- Catch and dispose of escaping coolant.

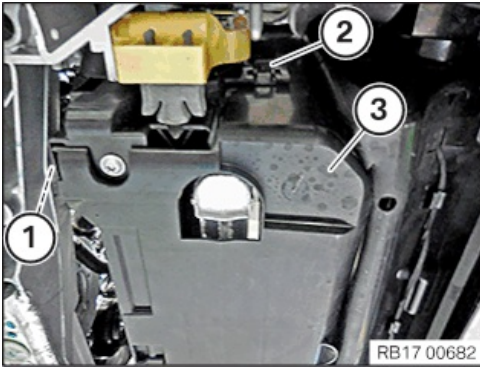

- Unlock lock (1).
- Unlock lock (2).
- Release the cover (3) of the cooling module at the bottom.



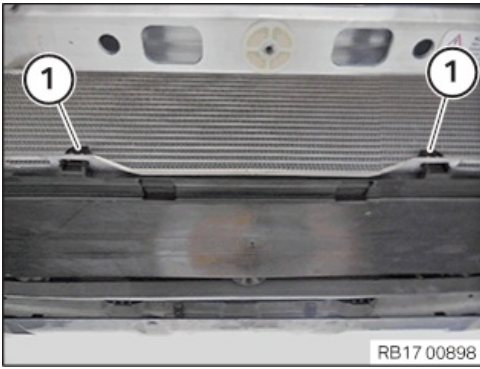

- Unlock the locks (1).

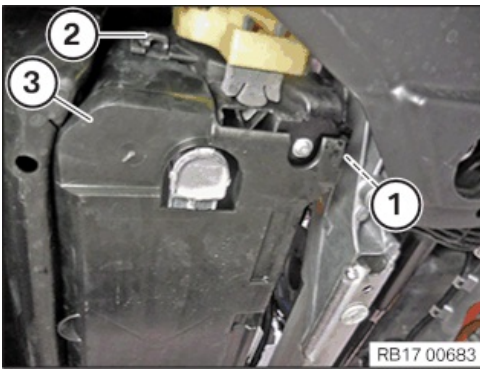

- Unlock lock (1).
- Unlock lock (2).
- Remove the cover (3) of the bottom cooling module.

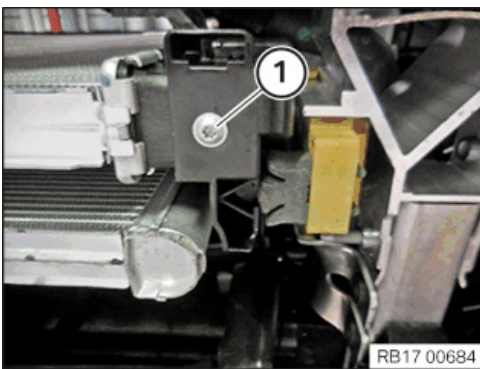

- Loosen screw (1).

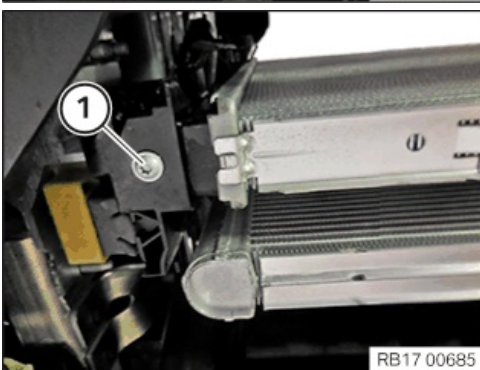

- Loosen screw (1).



- Unlock the transmission oil feed line (1) and pull it off the transmission oil cooler.
- Catch and dispose of escaping transmission oil.



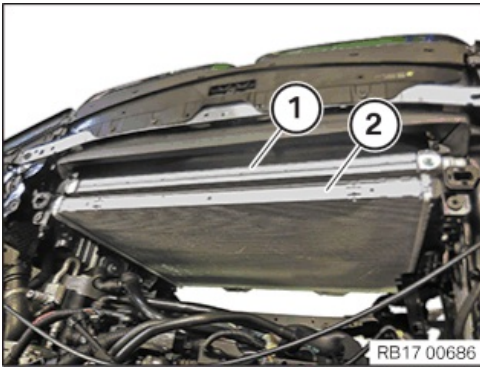

- Remove the radiator of the low-temperature coolant circuit (1) including the radiator of the high-temperature coolant circuit (2).

10 – Renewing the radiator of the high-temperature coolant circuit



- Unlock and loosen the covers (1).

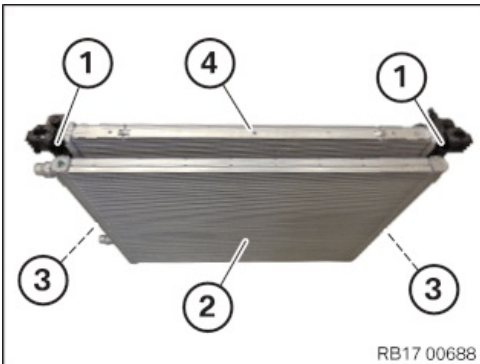

- Unlock the locks (1).
- Guide radiator of low-temperature coolant circuit (2) out of the guides (3) of the radiator of the high-temperature coolant circuit (4) and remove.
- Renew high temperature radiator (4).

Parts: Radiator of high-temperature coolant circuit (4)

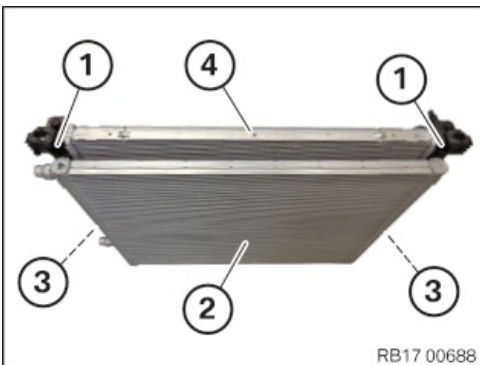

- Guide radiator of low-temperature coolant circuit (2) into the guides (3) of the radiator of the high-temperature coolant circuit (4) and install. The locks (1) must engage audibly.



- Guide in and install cover (1).

11 – Install the radiator of the high-temperature coolant circuit





TECHNICAL INFORMATION

Notes on work at the cooling system form the basis of these repair instructions and must be complied with at all times.
For additional information see: 17 00 ... Instructions for repair work on cooling system



TECHNICAL INFORMATION

Make sure that the connections are locked correctly. The locks must engage audibly.

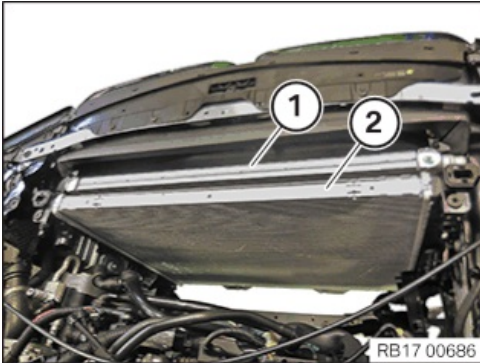

- Guide in radiator of low-temperature coolant circuit (1) with radiator of high-temperature coolant circuit (2) and install.

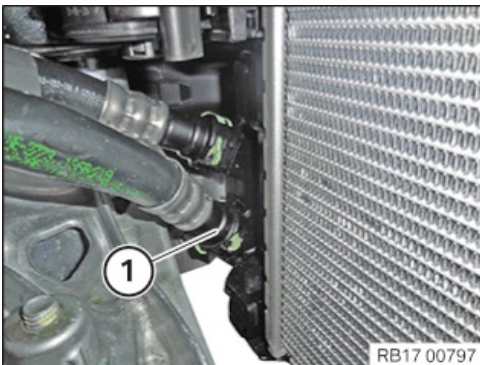

- Connect the transmission oil feed line (1) to the transmission oil cooler and lock.

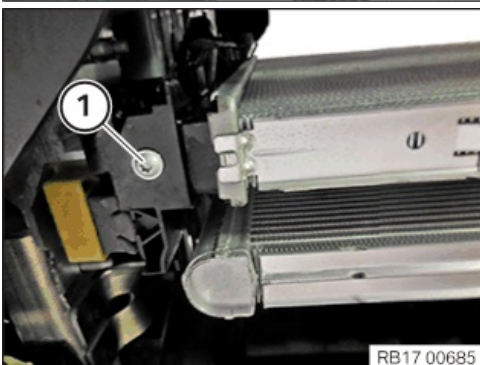

- Tighten screw (1) on bottom cooling module, left.

Radiator to cooling module, bottom

| | | | |
|--------|--|-------------------|------|
| TS6x20 | | Tightening torque | 6 Nm |
|--------|--|-------------------|------|

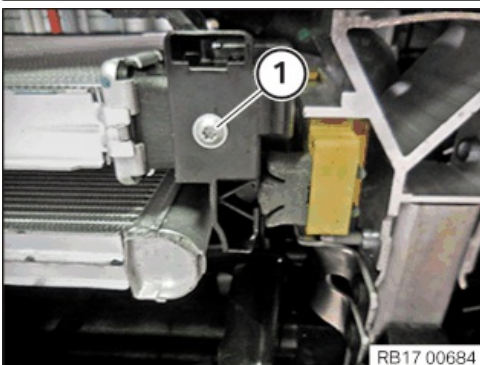

- Tighten screw (1) on bottom cooling module, right.

Radiator to cooling module, bottom

| | | | |
|--------|--|-------------------|------|
| TS6x20 | | Tightening torque | 6 Nm |
|--------|--|-------------------|------|



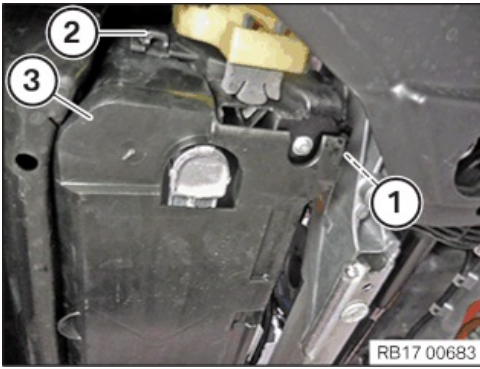

- Insert and install the cover (3) at the bottom left cooling module.
- Ensure that the lock (2) engages audibly.
- Ensure that the lock (1) engages audibly.

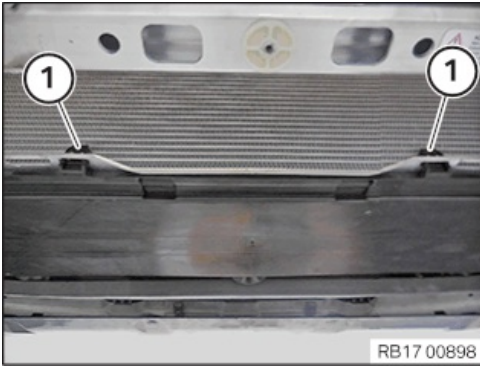

- Ensure that the locks (1) engage audibly.

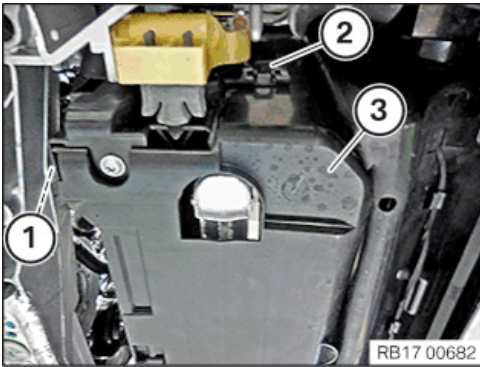

- Feed in and install cover (3) on cooling module, bottom right.
- Ensure that the lock (2) engages audibly.
- Ensure that the lock (1) engages audibly.



- Connect and lock coolant line (1).
- Make sure that the coolant line (1) engages audibly.

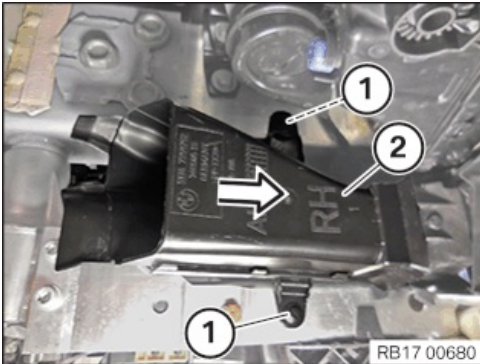

- Feed in air duct (2) in direction of arrow and install.
- Secure clamps (1).



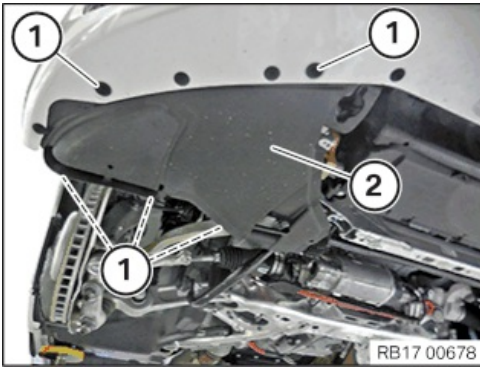

- Guide in and install cover (2), front right.
- Secure the clamps.
- Tighten the screws (1).

Cover to front bumper

| Screw | Tightening torque |
|-------|-------------------|
| | 3 Nm |

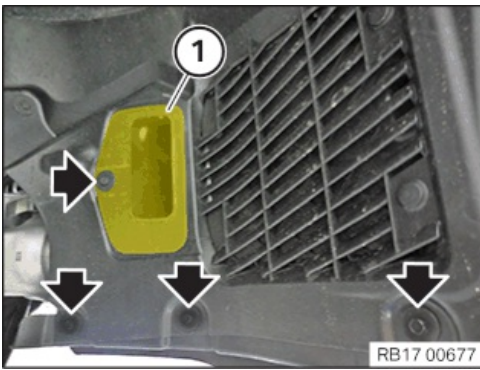

- Thread in air duct (1) and install.
- Tighten screws (arrows).

Cover to front bumper

| Screw | Tightening torque |
|-------|-------------------|
| | 3 Nm |

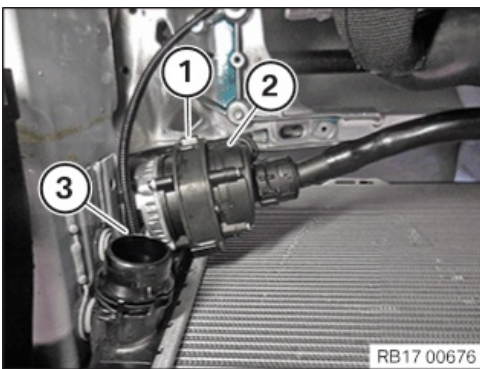

- Feed in and install the electric coolant pump (2).
- Secure the holder (1).
- Secure clamps (3).

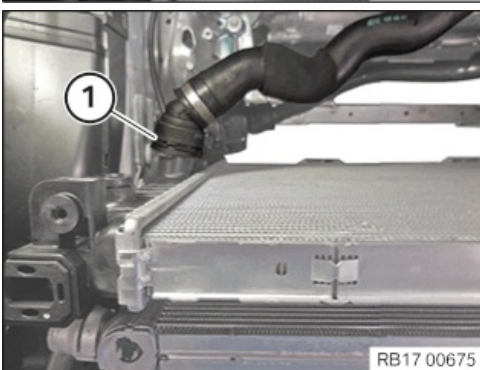

- Connect and lock coolant line (1).
- Make sure that the cooling line (1) engages audibly.

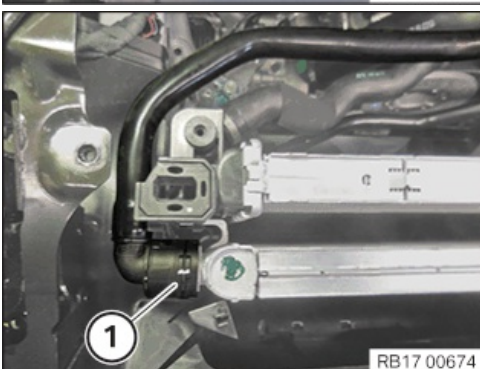

- Connect and lock coolant line (1).
- Make sure that the cooling line (1) engages audibly.



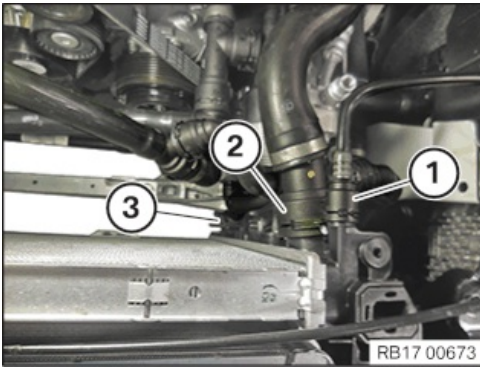

NOTICE

The following work step(s) is / are to be carried out if the specified component(s) is/are fitted.

- Connect and lock coolant line (3).
- Connect and lock coolant line (2).
- Connect and lock coolant line (1).
- Make sure that the coolant lines engage audibly.
- Guide in and install cover (3) on cooling module at the top.
- Ensure that the locks (2) engage audibly.
- Ensure that the locks (1) engage audibly.



POSTPROCESSES

12 – Install fan cowl

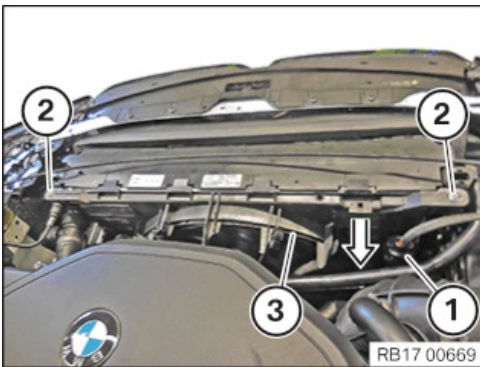

- Feed in and install the fan cowl (3) in the direction of the arrow.
- Tighten the screws (2).

Fan cowl on radiator

TS6x20

6 Nm

- Connect and lock the connector (1).
The connector (1) must engage audibly.

• If fitted:

Fasten the coolant line (1) below at the fan cowl with the clamps.

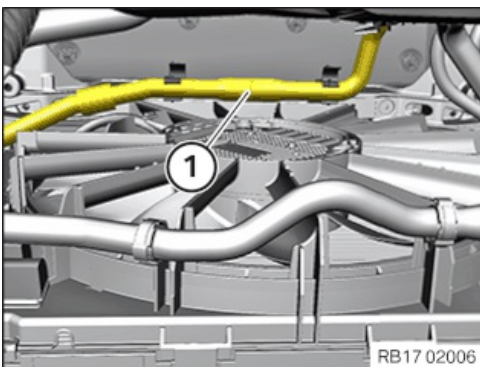

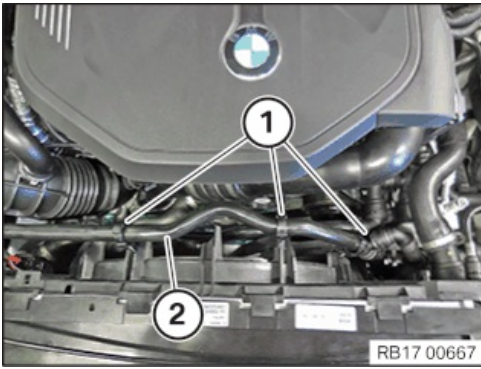

- Feed in and install coolant line (2).
- Lock clamps (1).
The clamps (1) must engage audibly.

13 – Install the rear top cross connection

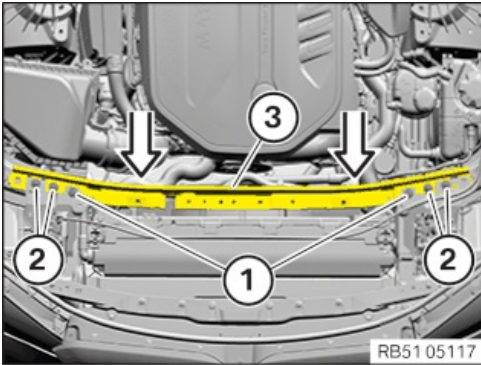

- Guide the cross connection (3) in from the rear in the direction of arrow.
- Tighten down screws (1) and (2).

Top rear cross connection

| | | |
|------------------------|-------------------|-------|
| Torx screw M8x30 | Tightening torque | 19 Nm |
| Hexagon screw M8x20 | Tightening torque | 19 Nm |

14 – Install front cross connection

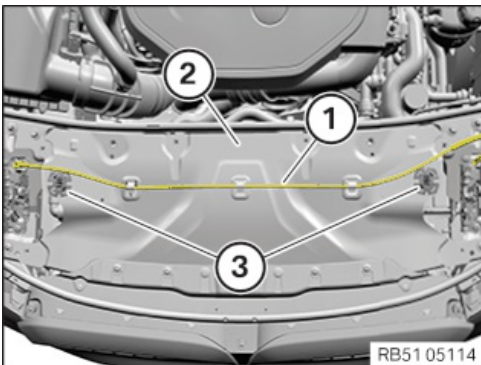

- Feed in cross connection (2) with brackets (3).
- Attach the Bowden cable (1).

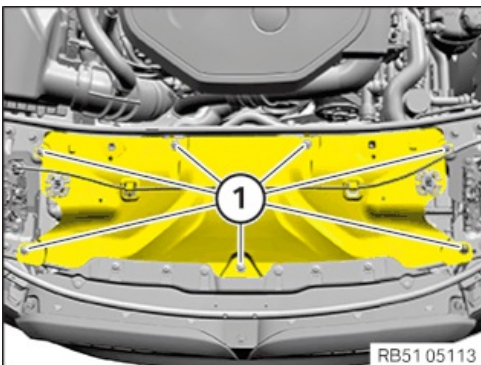

- Tighten the screws (1).

Front cross connection

| | | |
|-------|-------------------|---------|
| Screw | Tightening torque | 11,8 Nm |
|-------|-------------------|---------|

15 – Installing both front-end struts



NOTICE

Description is for right component only. The procedure on the left side is identical.

► Installing the front-end strut



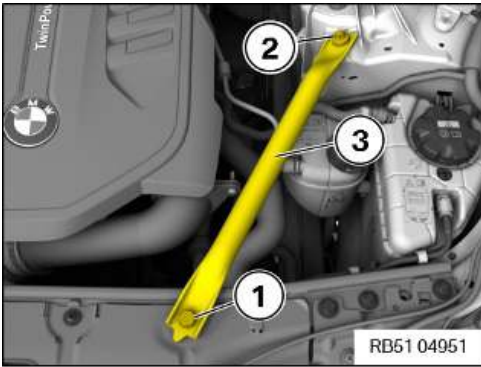

- Install the front-end strut (3).



RISK OF DAMAGE

Use of an incorrect tool (impact screwdriver) to release and tighten the screws.

Damaged thread.

- Only use a standard tool (e.g. reversible ratchet) to release/tighten the screw.

- Clean threads on spring strut dome.
- Renew the screw (1).

Parts: Screw

- Tighten down screw (1).

Front-end strut to cross connection

| | | | |
|---------------|--------------|-------------------|-------|
| Hexagon screw | Renew screw. | Jointing torque | 28 Nm |
| | | Angle of rotation | 90 ° |

- Renew the screw (2).

Parts: Screw

- Tighten down screw (2).

Front end strut

| | | | |
|-------|--------------|-------------------|-------|
| Screw | Renew screw. | Jointing torque | 56 Nm |
| | | Angle of rotation | 90 ° |

- Repair damaged threads on the spring strut dome with a Helicoil insert.

Expendable materials

| | | |
|------------------------|-----------|-------------|
| Helicoil thread insert | M10x30 mm | 07129909659 |
|------------------------|-----------|-------------|

16 – Installing the cover on the left and right in the top engine compartment



NOTICE

Description is for left component only. Procedure on the right side is identical.

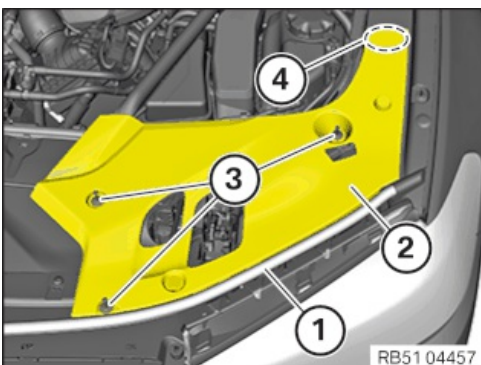

► Install the cover in the engine compartment on top

- Insert the cover (2) in the area (4).
- Secure expanding rivet (3).
- Mount seal (1) on cover (2).

17 – Filling and bleed the high-temperature coolant circuit





TECHNICAL INFORMATION

It is **mandatory** to fill the cooling system before bleeding.
Fill **both** the circuits for high and low-temperature coolant circuits.

- See additional information.

18 – Filling and bleed the low-temperature coolant circuit



TECHNICAL INFORMATION

It is **mandatory** to fill the cooling system before bleeding.
Fill **both** the circuits for high and low-temperature coolant circuits.

- See additional information.

19 – Checking/topping up oil level in automatic transmission

Prerequisite

Vehicle is in a horizontal position.

The vehicle is secured against rolling away.



CAUTION

Materials harmful to health.

Contact with fluids harmful to health!

- Note and follow safety information on containers.
- Conduct all work in appropriate personal protective equipment only.



TECHNICAL INFORMATION

To set the correct oil level, it is mandatory that the service function "Transmission control unit: Oil-level adjustment" is carried out with the diagnosis system.



TECHNICAL INFORMATION

Carry out oil-level adjustment:

Certain fault memory entries may require an oil-level adjustment in the automatic transmission and after repairs have been completed (e.g. exchange of mechatronics, exchange of the converter, exchange of the transmission, automatic transmission oil service).





TECHNICAL INFORMATION

The automatic transmission fluid specified by BMW must be used for the automatic transmission.

For additional information see: SBS-ANL-SBS1996-240596143_A14 (automatic transmission fluid for ZF transmissions, etc.)

- Connect diagnosis system.
- Observe the predefined transmission oil temperatures for the oil-level adjustment with the diagnosis system:
 - Initial condition: Transmission oil temperature 30°C to 40°C.
 - Final condition: Transmission oil temperature 40°C to 50°C.
- Call up service function (drive).
- Carry out oil-level adjustment in accordance with the instructions.
- Loosen the oil filler plug (1) using the special tool [2 405 614](#).
- Top up automatic transmission fluid according to the instructions in the diagnosis system.

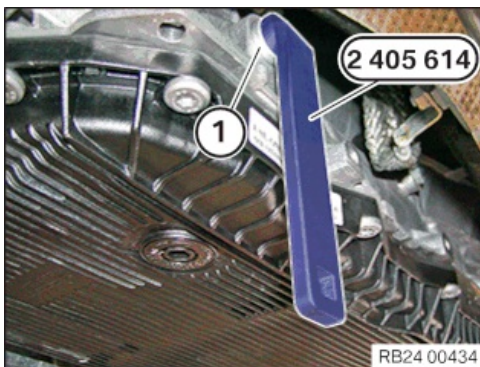

GA8HP51Z transmission capacity

min. 9,28 l

Transmission oil: Automatic transmission fluid ATF 3+

GA8HP76Z transmission capacity

min. 9,35 l

Transmission oil: Automatic transmission fluid ATF 3+

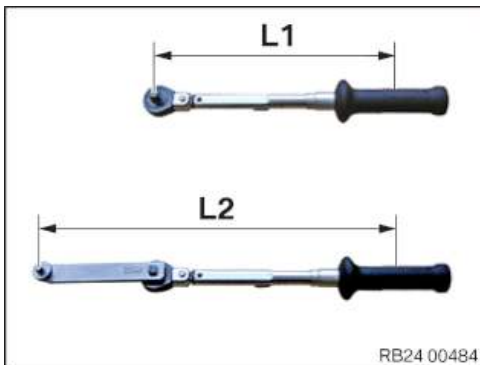

TECHNICAL INFORMATION

The setpoint torque deviates from the torque to be set when using special tool 2 405 614.

- Converting the setpoint torque into the torque to be set:
(setpoint torque x L1) : L2 = Torque to be set
L1 = Length from the centre of the handle to the reversible ratchet head
L2 = Length from the centre of the handle to the engaging of the special tool in the bolt

- Renew the oil filler plug (1) and the sealing ring.

Parts: Oil filler plug, sealing ring

- Make sure that the special tool [2 405 614](#) and the torque wrench (2) align while tightening the oil filler plug (1).
- Tighten the oil filler plug (1) with the special tool [2 405 614](#) and the torque wrench (2).

Oil filler plug

M18x1.5

Tightening torque

35 Nm

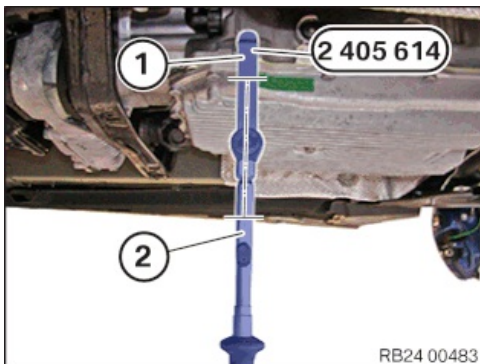



TECHNICAL INFORMATION

Different variants may be installed depending on the vehicle equipment.

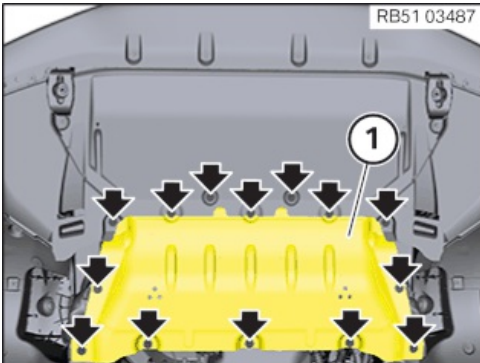

- **Version A:**

Insert steering gear aggregate protective plate (1).

Tighten screws (arrows).

Underbody protection

| | | | |
|-------|--|-------------------|------|
| Screw | | Tightening torque | 3 Nm |
|-------|--|-------------------|------|

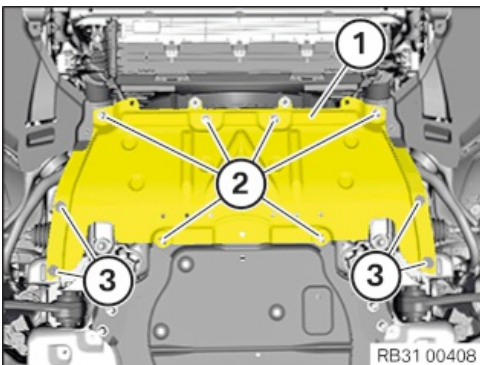

- **Version B:**

Renew screws (2).

Parts: Screws

Position the front stiffening plate (1).

Tighten the screws (2).

Stiffening plate to front axle support

| | | | |
|----|---------------|-------------------|-------|
| M8 | Renew screws. | Jointing torque | 25 Nm |
| | | Angle of rotation | 70 ° |

- Tighten the screws (3).

Cover, steering unit

| | | | |
|-------|--|-------------------|------|
| Screw | | Tightening torque | 3 Nm |
|-------|--|-------------------|------|

21 – Install front underbody protection and/or front stiffening plate



TECHNICAL INFORMATION

Different variants may be installed depending on the vehicle equipment.

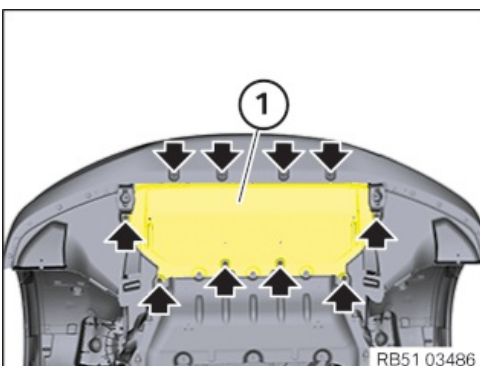

- **Version A:**

Insert the front underbody protection (1).

Tighten screws (arrows).

Underbody protection

| | | | |
|-------|--|-------------------|------|
| Screw | | Tightening torque | 3 Nm |
|-------|--|-------------------|------|



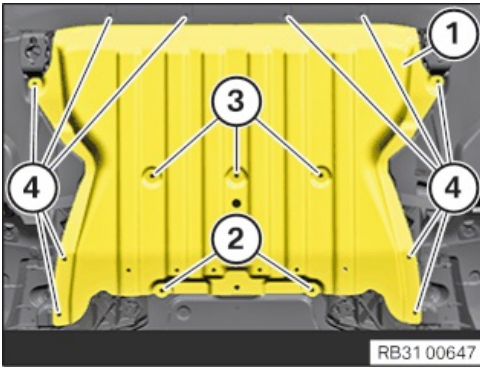

• **Version B:**

Position the front stiffening plate (1).

Renew screws (2).

Parts: Screws

Tighten the screws (2).

Stiffening plate to front axle support

| | | | |
|----|---------------|-------------------|-------|
| M8 | Renew screws. | Jointing torque | 25 Nm |
| | | Angle of rotation | 70 ° |

• Tighten the screws (3).

• Tighten the screws (4).

Underbody protection

| | | | |
|-------|--|-------------------|------|
| Screw | | Tightening torque | 3 Nm |
|-------|--|-------------------|------|

22 – Installing underbody protection at rear



NOTICE

To provide a better overview: Schematic diagram with partially hidden components.

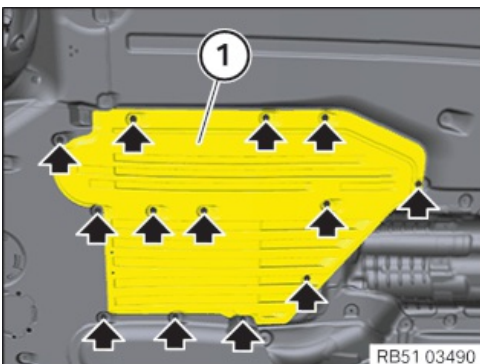

• **Version A:**

Insert the rear underbody protection (1).

Tighten screws (arrows).

Underbody panelling

| | | | |
|-------------|--|-------------------|--------|
| Screw | | Tightening torque | 2,6 Nm |
| Plastic nut | | Tightening torque | 2,6 Nm |

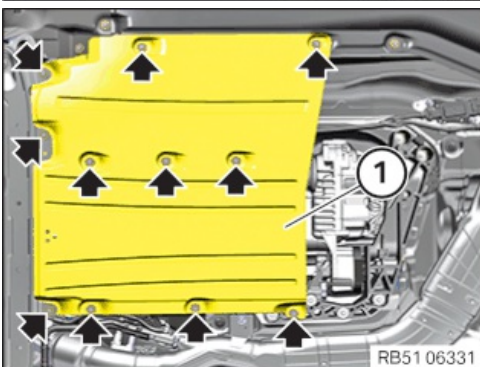

• **Version B:**

Insert and install the rear underbody protection (1).

Tighten screws (arrows).

Underbody panelling

| | | | |
|-------------|--|-------------------|--------|
| Screw | | Tightening torque | 2,6 Nm |
| Plastic nut | | Tightening torque | 2,6 Nm |

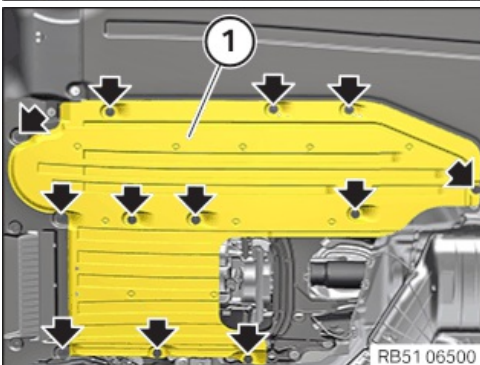

• **Version C:**

Insert and install the rear underbody protection (1).

Tighten screws (arrows).

Underbody panelling

| | | | |
|-------------|--|-------------------|--------|
| Screw | | Tightening torque | 2,6 Nm |
| Plastic nut | | Tightening torque | 2,6 Nm |



Additional Information

Overview of Tightening Torques

| | | | |
|---|---------------|-------------------|-------------------|
| Radiator to cooling module, bottom | | | Used in step 11 |
| TS6x20 | | Tightening torque | 6 Nm |
| Cover to front bumper | | | Used in step 11 |
| Screw | | Tightening torque | 3 Nm |
| Fan cowl on radiator | | | Used in step 12 |
| TS6x20 | | | 6 Nm |
| Top rear cross connection | | | Used in step 13 |
| Torx screw M8x30 | | Tightening torque | 19 Nm |
| Hexagon screw M8x20 | | Tightening torque | 19 Nm |
| Front cross connection | | | Used in step 14 |
| Screw | | Tightening torque | 11,8 Nm |
| Front-end strut to cross connection | | | Used in step 15 |
| Hexagon screw | Renew screw. | Jointing torque | 28 Nm |
| | | Angle of rotation | 90 ° |
| Front end strut | | | Used in step 15 |
| Screw | Renew screw. | Jointing torque | 56 Nm |
| | | Angle of rotation | 90 ° |
| Oil filler plug | | | Used in step 19 |
| M18x1.5 | | Tightening torque | 35 Nm |
| Underbody protection | | | Used in step 2021 |
| Screw | | Tightening torque | 3 Nm |
| Stiffening plate to front axle support | | | Used in step 2021 |
| M8 | Renew screws. | Jointing torque | 25 Nm |
| | | Angle of rotation | 70 ° |
| Cover, steering unit | | | Used in step 20 |
| Screw | | Tightening torque | 3 Nm |
| Underbody panelling | | | Used in step 22 |
| Screw | | Tightening torque | 2,6 Nm |
| Plastic nut | | Tightening torque | 2,6 Nm |

Overview of Special Tools



2 405 614 Socket wrench



Common

Used in step 19

Usage

For opening and closing the oil filler plug. Contour-graphic silhouette foil is included in delivery specification. Further information on the contour-graphic silhouette foil can be found in service information 00 22 13 (969). Replaced by 2455997

Included in the tool or work

Storage location

Replaced by

In connection with

SI-Number 01 33 15 (305)

Overview Technical Data

GA8HP51Z transmission capacity

Used in step 19

min. 9,28 l

Transmission oil: Automatic transmission fluid ATF 3+

GA8HP76Z transmission capacity

Used in step 19

min. 9,35 l

Transmission oil: Automatic transmission fluid ATF 3+

Links

Repair instructions

Used in step

| | |
|--|-----|
| 17 00 ... Instructions for repair work on cooling system | 911 |
| 17 00 008 Draining and topping up coolant for high-temperature circuit | 17 |
| 17 00 039 Bleed the cooling system and check it for watertightness with the special tool | 17 |
| 17 00 039 Bleed the cooling system and check it for watertightness with the special tool | 17 |
| 17 00 039 Bleed the cooling system and check it for watertightness with the special tool | 17 |
| 17 00 008 Draining and topping up coolant for high-temperature circuit | 17 |
| 17 00 008 Draining and topping up coolant for high-temperature circuit | 17 |
| 17 00 008 Draining and topping up coolant for high-temperature circuit | 17 |
| 17 00 008 Draining and topping up coolant for high-temperature circuit | 17 |
| 17 00 039 Bleed the cooling system and check it for watertightness with the special tool | 17 |
| 17 00 039 Bleed the cooling system and check it for watertightness with the special tool | 17 |
| 17 00 039 Bleed the cooling system and check it for watertightness with the special tool | 17 |
| 17 00 039 Bleed the cooling system and check it for watertightness with the special tool | 17 |
| 17 00 039 Bleed the cooling system and check it for watertightness with the special tool | 17 |



| | |
|---|------|
| 17 00 039 Bleed the cooling system and check it for watertightness with the special tool | 17 |
| 17 00 039 Bleed the cooling system and check it for watertightness with the special tool | 17 |
| 17 00 039 Bleed the cooling system and check it for watertightness with the special tool | 17 |
| 17 00 039 Bleed the cooling system and check it for watertightness with the special tool | 17 |
| 17 00 040 Bleed the cooling system and check for watertightness with the special tool (coolant circuit for low temperature) | 1718 |
| 17 00 039 Bleed the cooling system and check it for watertightness with the special tool | 17 |
| 17 00 009 Check the cooling system for watertightness with a special tool (with a tester) | 17 |
| 17 00 009 Check the cooling system for watertightness with a special tool (with a tester) | 17 |
| 17 00 039 Bleed the cooling system and check it for watertightness with the special tool | 17 |
| 17 00 008 Draining and topping up coolant for high-temperature circuit | 17 |
| 17 00 039 Bleed the cooling system and check it for watertightness with the special tool | 17 |
| 17 00 039 Bleed the cooling system and check it for watertightness with the special tool | 17 |
| 17 00 008 Draining and topping up coolant for high-temperature circuit | 17 |
| 17 00 039 Bleed the cooling system and check it for watertightness with the special tool | 17 |
| 17 00 039 Bleed the cooling system and check it for watertightness with the special tool | 17 |
| 17 00 039 Bleed the cooling system and check it for watertightness with the special tool | 17 |
| 17 00 011 Draining and topping up the coolant for the low-temperature circuit | 18 |
| 17 00 040 Bleed the cooling system and check for watertightness with the special tool (coolant circuit for low temperature) | 18 |
| 17 00 040 Bleed the cooling system and check for watertightness with the special tool (coolant circuit for low temperature) | 18 |
| 17 11 103 Removing and installing/replacing coolant expansion tank for the low-temperature coolant circuit | 18 |
| 17 11 103 Removing and installing/replacing coolant expansion tank for the low-temperature coolant circuit | 18 |
| 17 00 040 Bleed the cooling system and check for watertightness with the special tool (coolant circuit for low temperature) | 18 |
| 17 00 040 Bleed the cooling system and check for watertightness with the special tool (coolant circuit for low temperature) | 18 |
| 17 00 040 Bleed the cooling system and check for watertightness with the special tool (coolant circuit for low temperature) | 18 |
| 17 00 040 Venting cooling system and checking on watertightness | 18 |
| 17 00 040 Venting high temperature - cooling system and checking for water leaks (N20 hybrid drive) | 18 |
| 17 00 040 Venting high temperature - cooling system and checking for water leaks (N20 hybrid drive) | 18 |
| 17 00 040 Bleeding lower-temperature cooling system (B48) | 18 |
| 17 00 040 Bleed the cooling system and check for watertightness with the special tool (coolant circuit for low temperature) | 18 |
| 17 00 040 Bleed the cooling system and check for watertightness with the special tool (coolant circuit for low temperature) | 18 |
| 17 00 040 Bleed the cooling system and check for watertightness with the special tool (coolant circuit for low temperature) | 18 |
| 17 00 040 Bleed the cooling system and check for watertightness with the special tool (coolant circuit for low temperature) | 18 |
| 17 00 040 Bleed the cooling system and check for watertightness with the special tool (coolant circuit for low temperature) | 18 |
| 17 00 040 Bleed the cooling system and check for watertightness with the special tool (coolant circuit for low temperature) | 18 |
| 17 00 011 Draining and topping up coolant circuit for low temperature | 18 |
| 17 00 040 Bleed the low-temperature cooling system and check for watertightness (coolant circuit for low temperature) | 18 |
| 17 00 040 Bleeding and filling low temperature cooling system using vacuum filler device (B48) | 18 |



| | |
|---|----|
| 17 00 011 Draining and topping up low-temperature coolant circuit | 18 |
| 17 00 011 Draining and topping up low-temperature coolant circuit | 18 |
| 17 00 040 Bleeding the low-temperature coolant circuit and checking it for watertightness | 18 |
| 17 00 040 Bleeding the low-temperature coolant circuit and checking it for watertightness | 18 |
| 17 00 015 Draining and topping up the coolant circuit for the drive IPREMIUM | 18 |
| 17 00 011 Draining and topping up low-temperature coolant circuit | 18 |
| 17 00 040 Bleed the cooling system and check for watertightness with the special tool (low-temperature coolant circuit) | 18 |
| 17 00 040 Bleed the cooling system and check for watertightness with the special tool (coolant circuit for low temperature) | 18 |
| 17 00 040 Bleed the cooling system and check for watertightness with the special tool (coolant circuit for low temperature) | 18 |
| 17 00 040 Bleed the cooling system and check for watertightness with the special tool (coolant circuit for low temperature) | 18 |
| 17 00 040 Bleed the cooling system and check for watertightness with the special tool (coolant circuit for low temperature) | 18 |
| 17 00 040 Bleed the cooling system and check for watertightness with the special tool (coolant circuit for low temperature) | 18 |
| 17 00 040 Bleed the cooling system and check for watertightness with the special tool (coolant circuit for low temperature) | 18 |
| 17 00 040 Bleed the cooling system and check for watertightness with the special tool (coolant circuit for low temperature) | 18 |
| 17 00 040 Bleed the cooling system and check for watertightness with the special tool (coolant circuit for low temperature) | 18 |
| 17 00 040 Bleed the cooling system and check for watertightness with the special tool (coolant circuit for low temperature) | 18 |
| 17 00 040 Bleed the cooling system and check for watertightness with the special tool (coolant circuit for low temperature) | 18 |
| 17 00 040 Bleed the cooling system and check for watertightness with the special tool (coolant circuit for low temperature) | 18 |
| 17 00 040 Bleed the cooling system and check for watertightness with the special tool (coolant circuit for low temperature) | 18 |

| Operating materials | Used in step |
|--|---------------------|
| 14.0 Automatic transmission fluid for ZF-transmission GA8HP45Z / GA8HP50Z / GA8HP70Z / GA8HP90Z / GA8P70H / GA8P75H / GA8HP75Z | 19 |

| Operating materials | Used in step |
|----------------------------|---------------------|
| Main group 17 | 9 |

